

Combustion Module by Costech for CM-CRDS



Picarro

Picarro, Inc.

3105 Patrick Henry Drive
Santa Clara, CA 95054 - USA
Phone: (408) 962-3900
Fax: (408) 962-3200
info@picarro.com
www.picarro.com

1. INTRODUCTION

Thank you for purchasing the Combustion Module from Costech Analytical Technologies, Inc. The **Combustion Module** is an advanced analytical platform for CO₂ isotopic analysis when coupled to the Picarro Liaison and CRDS CO₂ isotopic analyzer. It is based on an automatic analytical unit whose operation is microprocessor controlled.



Three sample size ranges can be selected for all combustion versions: MICRO, SEMIMICRO and MACRO. This allows the operator to choose the correct amount of oxygen for different sample types and sizes.

To reduce the cost of analysis it is important to increase the number of samples which can be run using the minimum amount of catalysts, and to reduce the cost of disposal of the exhausted catalysts and reagents.

Our approach to the design of the CM, was to produce an instrument which could function as a “combustion analytical platform” for many different applications. It needed to be flexible, easy to use, and of course, produce superior analytical results.

TABLE OF CONTENT

1. Introduction

2. Physical Inspection and Setup of Base Unit

- 2.1 Inspection
- 2.2 Standard Outfit
- 2.3 Gases and Electrical Specifications
- 2.4 Installing the Combustion Module
 - 2.4.1 Connecting the Gases
 - 2.4.2 Installing the Combustion Reactor
 - 2.4.3 Autosampler Installation
 - 2.4.4 Water Trap Installation
- 2.5 Switching the Combustion Module On
- 2.6 Turn on the Gases
 - 2.6.1 Leak Testing Procedure
- 2.7 Setting the Operational Parameters and Gas Flow Rates

3. Base Unit Description

- 3.1 Front View
- 3.2 Gas Control Panel
- 3.3 Rear View
- 3.4 Furnace
- 3.5 Water Trap
- 3.6 Pneumatic Autosampler
 - 3.6.1 Installation and Operation
 - 3.6.2 Replacing the Main O-rings
- 3.7 Pneumatic Section
 - 3.7.1 Photo of Pneumatic Section
 - 3.7.2 Topographic Diagram

4. Keyboard Commands and Operations

- 4.1 Keyboard
 - 4.1.1 Keyboard Description
- 4.2 Introduction
- 4.3 Starting Off
 - 4.3.1 Step1: Power On
 - 4.3.2 Step 2: Going to the Main Menu
 - 4.3.3 Step 3: Setting the Temperature
 - 4.3.4 Step 4: Setting the Time Cycle

- 4.3.5 Setting the Autosampler Mode
- 4.4 Operation Key Explanations
- 4.5 Alarms and Warnings
- 4.6 Alarm LED's

5. Operating Principle

6. Reactors and Traps - Packing Diagram

- 6.1 Reactor Packing Diagram
- 6.2 Packing the H₂O Trap
- 6.3 Installing Reactor and Trap - Leak Checking
- 6.4 Setting flow rates
 - Nitrogen
 - Oxygen

7. Connecting the start signal cable

- 7.1 Liaison to Combustion Module

8. CM Operating Parameters

- 8.1 ¹³C Isotopic Analysis
- 8.2 Performing an Analysis
- 8.3 Solid Sample Preparation Technique
- 8.4 Principle of Operation
- 8.5 Analysis Cycle
- 8.6 Replacing the Ash Crucible

9. Sample Preparation

- 9.1 Sample Preparation Tools
- 9.2 Liquid Sample Technique
- 9.3 Capsules

2. PHYSICAL INSPECTION AND SET UP OF BASE UNIT

- 2.1 1) A careful inspection of the CM is very important. Check for any shipping damage and report it as soon as possible.
- 2) Check the standard outfit for completeness, and report any missing items.

2.2 The base unit will be completed with the standard outfit listed below:

HARDWARE

Qty.	Part number	Description
2	080011	SS tubing, 3 meters
1	080012	5x3 Polyethylene tubing, 5 meters
2	080027	Nut for polyethylene tubing
2	080018	Pak of 2, Nuts for Blue tubing
2	080022	Caps for Air lines, includes rubber insert
1	071120	H ₂ O Trap (installed in CM unit)
1	080001	Pack of Nuts for 2 mm tubing,
1	080002	Pack of Ferrules for 2 mm tubing
1	080026	Pack of Ferrules for 1/16" tubing
4	080017	Unions (for connecting 2 mm tubing)
2	080030	Connector for H2O trap (installed in CM)
1	080010	Teflon tubing, 5 M
5	080013	Blanking nut, brass (installed on CM)
2	080020	Connector for exit vent of CM
1	096026	Large nut for autosampler (installed on CM)
1	102013309	Top thermal insulating collar
1	102013308	Bottom thermal insulating collar
2	103026304	Fuse
1	202014301	Sample holder plate
1	080007	Sample preparation plate
1		Swagelok fittings (bag of assorted fittings)

CONSUMABLES & REAGENTS

1	05108X	Short GC Column (Installed in the CM)
4	041070	Tin capsules 4x6 mm
1	021035	10g Quartz wool
1	021025	Quartz chips
1	021022	Magnesium perchlorate
2	071122	Seals for traps
4	061116	Seals for top of combustion tube
4	061140	Seals for bottom of combustion tube
1		Standards (Acetanilide or Atropine)
2	061134	Pre-packed combustion reactor
2	061150	Alumina insert for ash removal
1		Chromium oxide catalyt for alumina insert, 10g

ACCESSORIES

1	080007	Sample Prep plate
2	080006	Forceps
1	080005	Spatula
1	080028	Bubble Flowmeter
1	084010	Tool for combustion tube removal
1	084005	Tongs for removing the alumina insert
1	084007	Spanner wrench
1		Wooden dowels for reactor tube packing

2.3 Instrument Set-up

Gases:

Nitrogen	99.999%	Delivery pressure - 35-40 psi
Oxygen	99.995% or higher	Delivery pressure - 30 psi
Air	Water and oil free	Delivery pressure - 45-60 psi

Regulators should be two stage with Stainless Steel diaphragms. They should be capable of delivering the required pressure for each gas. If the CM will be installed within 6-8 feet of the gas cylinders, provide 1/8" Swagelok™ fittings for the Nitrogen and Oxygen lines, and a 1/4" Swagelok™ fitting for the Air. If the cylinders are further than 8 feet from the analyzer, use SS or copper tubing to bring the gases to the back of the analyzers, and end with the correct Swagelok™ fittings.

Electric power:

- Nominal 208-220V 50/60 Hz
- At lower voltages the furnace heating time will increase.
- Provide the correct plug for your electrical outlet.

2.4 Installing the Combustion module

Combustion Module Installation Instructions

- 1) Remove the Combustion Module (CM) from the shipping crate and vacuum out any debris which has fallen out of the furnace cabinet. Shipping can create a lot of dust from the furnace insulation; this is normal. The insulation is an extremely efficient material, but it throws off a lot of debris in shipment.
- 2) **Important:** There is a warning label on the front of the CM which instructs you to remove the shipping insert from the furnace. This is a length of PVC tubing which is held in place by the large nut and seal on top of the CM. Remove the nut and pull out the PVC shipping insert.
- 3) Remove the three screws holding the round flange in place on top of the CM. This is to allow you to install the Top Thermal Collar, part number 102013309, from the installation kit. This thermal collar sits on top of the furnace cabinet and is left in place permanently. It is installed with the side which has the ridge in the down position. The ridge fits into the top of the furnace cabinet and prevents the thermal collar from moving after installation. The combustion reactor will slide through this thermal collar and down into the furnace.
- 4) Replace the top round flange and secure it using the three screws.

2.4.1 Connecting the gases

- 5) At the back of the CM there are three connection for 1) the N₂ carrier gas, 2) oxygen for combustion, 3) and the pneumatic gas. The pneumatic gas can be either Air or N₂, oil and water free. It is not an analytical gas; it is simply used to operate the PN150 autosampler.
- 6) Remove the brass plugs in the Carrier gas and Oxygen inlet bulkhead fittings.
- 7) Locate the two lengths of 2 mm Stainless Steel tubing in the installation kit, part number 080011. These will be used to connect the analytical gases, N₂ and O₂.
- 8) Connect the 2 mm SS tubing to the gas cylinders using the appropriate fittings. We have supplied a bag of Swagelok fittings for this purpose. If these are not suitable for your installation you will need to find fittings which can be used to connect the 2 mm tubing to the gas regulators.
- 9) Before connecting the tubing to the back of the CM turn on the gases one at a time and allow it to flush out any tiny particles which may be in the tubing. We recommend tapping the tubing to knock anything loose from the inside walls.
- 10) Two of the 6M nuts (part number 080001) and 2 mm ferrules (part number 080002) will be used for the connections at the back of the CM. Slide the nut onto the SS tubing and then a ferrule with the tapered end towards the end of the tubing. Slide the tubing all the way into the bulkhead fittings (N₂ carrier gas and oxygen) and tighten the nut which presses the ferrule tightly onto the tubing creating a seal. This requires an 8 mm wrench for the nut and a 14 mm wrench to hold the bulkhead fitting. Do not over tighten the nut.

- 11) The blue polyethylene tubing (part number 080012) is used for connecting the pneumatic gas. Connect one end to the gas regulator and the other end to the Air port on the back of the CM using one of the “knurled” nuts (part number 080027). Hand tighten the nut then use an 8 mm wrench to give it 1-2 extra turns to be sure it makes a good seal. Do not over tighten the nut.

2.4.2 Installing the Combustion Reactor

- 12) Locate the Combustion Reactor (part number 061134) from the installation kit. **Note the warning labels on the box.** They refer to a plastic shipping insert which is inside the reactor and must be removed prior to installation. Remove the warning sheet attached to the reactor, the end caps, and pull out the plastic shipping insert. If there is any separation of the catalysts or copper inside the reactor, tap it gently on a padded surface to settle the materials. If necessary, use the large wooden dowel in the installation kit to push down the quartz wool at the top of the reactor.
- 13) Prepare the Alumina Crucible which catches the residue from the sample combustion. This residue will include the tin dioxide from the tin capsule oxidation and any un-combusted sample material; for example from soil, sediment, glass fiber filters, etc. The alumina crucible is removed after a number of analyses and replaced. The alumina crucible can be reused until it cracks; there are two included in the installation kit. 1 cm of quartz wool is packed into one end of the crucible to provide a “bed” for the sample residue and approximately 2-3 mm of the chromium oxide catalyst (in the installation kit) is placed on top of the quartz wool. The chromium oxide catalyst is the same as that in the combustion reactor. Its function in the crucible is to provide a solid base for the collection of the sample residue; it does not melt or sinter at high temperature during the sample combustion (1600-1800 °C).
- 14) Keeping the combustion reactor in an upright position, use the Tongs provided (part number 084005) to insert the alumina crucible into the combustion reactor until it rests on the quartz wool in the middle of the reactor.
- 15) Place one of the seals for the top of the reactor (part number 061116) onto the top of the tube. It is installed with the narrow end at the top of the tube, the wider end toward the bottom. There should be approximately 3-4 mm of the tube exposed above the seal.
- 16) Locate the tool for installing and removing the combustion reactor (part number 084010). The tool expands an o-ring inside the reactor tube and then the tool acts as a handle making it easier to install and remove the reactor from the furnace. The end with the o-ring is inserted into the quartz combustion reactor and the larger end is turned clockwise to expand the o-ring. Once you feel the tool has a good grip on the reactor put the reactor aside, keeping it in the upright position so the chromium oxide in the crucible does not move, exposing the quartz wool. If it does, simply shake the tube slightly until the catalyst covers the quartz wool completely.
- 17) Below the furnace cabinet is a device which seals the bottom of the reactor. It has a handle which moves from right (loose position) to left (tightened position). Remove the device from the CM by removing the two thumb screws in the bottom of the cabinet. Do not lose the two small washers which are on the screws. There is a length of Teflon tubing attached to the device

which is long enough to allow you to remove it from the CM cabinet. The tubing connects the combustion reactor to the water trap.

- 18) Remove the shipping tape from the top of the sealing device and check to see if any material has gotten into the interior of the device. If so it must be cleaned out, otherwise it could inhibit the flow of carrier gas.
- 19) The device consists of a large nut with an attached handle, a metal washer and a green o-ring seal (part number 061140). Remove the large nut/handle by turning it counterclockwise and check that the metal washer and o-ring are in place. From top to bottom the order is 1) large nut with handle, 2) metal washer, 3) o-ring seal. Screw the nut back on the device to the correct position. When it is tight, with the handle to the left, move the handle to the right (the loose position) and place it aside.
- 20) Install the Bottom Thermal Collar (part number 102013308) in the small bracket at the bottom of the furnace cabinet. The flat side of the thermal collar will be installed towards the back of the CM, facing away from you.
- 21) Hold the reactor tube, with the top seal installed, by the tool and insert it into the furnace. It will slide through the top thermal collar, through the furnace, and out through the bottom thermal collar. You may have to move it around slightly to get it through the bottom thermal collar. Let it rest with the seal in the round flange on top of the CM. The seal will hold it in place while you re-install the bottom sealing device.
- 22) Put the bottom sealing device back into the CM cabinet. You will have to lift the reactor up a little bit in order to position the device below the reactor. Once the reactor is centered over the device (with the handle towards the right side, loose position) push down on the tube (Gently!) until it slides into the o-ring inside the sealing device; sometimes twisting it slightly helps. If the reactor is correctly seated the top seal will be sitting on the round flange with 2-3 mm of the reactor showing above it. If this is not the case the reactor is not seated correctly. Try pushing down a bit more being careful not to exert too much pressure on the reactor; you do not want to break the tube! If that does not work pull the tube out of the device and start again.
- 23) Once the reactor is fully seated turn the handle gently to the left until you feel the o-ring compress around the bottom of the tube making the seal. To make a good seal the handle will be approximately $\frac{3}{4}$ of the way to the left. **DO NOT OVERTIGHTEN!** You could break the tube.
- 24) Remove the tool from the top of the reactor by turning it counterclockwise, loosening the o-ring, and pulling the tool up and out of the reactor tube.

2.4.3 Autosampler installation

- 25) Remove the PN150 autosampler from its shipping box and check that it is complete. There should be the PN150 autosampler, a 50 position sample carousel, a stainless steel carrier gas line, a Teflon purge line, two pieces of the blue polyethylene tubing and four of the knurled nuts, a spare set of o-rings, and a small cone shaped tool which is used for removing the piston and installing the o-rings on the piston.
- 26) The leveling legs should not be extended until the autosampler is placed on the CM. If they are extended turn them to their shortest position. Place the autosampler carefully on top of the combustion tube being careful not to damage the tube. Position the autosampler at an angle

going to the right, away from combustion reactor. That will allow you to have access to the ports at the back of the CM. Hold the autosampler level with one hand and tighten the large nut which connects the autosampler to the combustion reactor. Once it's tight, lower the leveling legs until they contact the top of the CM. Check to see if the autosampler is visually level, if not it may be difficult to get a good seal.

- 27) Connect the blue Air lines. One line goes from port AS/1 to the connection on the side of the autosampler. The second line goes from port AS/2 to the connection at the back of the autosampler. Push the tubing completely onto the fittings and tighten down the knurled nuts on either end of the tube.
- 28) Connect the SS carrier gas line to the autosampler. The line is marked at both ends, Instrument and Autosampler. Remove the brass plugs from the ports on top of the CM marked Carrier and Purge (on the back of the CM). The Instrument side connects to the port marked Carrier, and the Autosampler side is connected to the port in the side of the autosampler tube which is mounted on the combustion reactor. The nuts are tightened using an 8 mm wrench.
- 29) Connect the purge line. The Teflon purge line is connected to the port on top of the CM marked Purge (on the back of the CM) and the port in the bottom of the autosampler. **Note:** Do not connect the tubing to the port in the bottom of the autosampler at this time.

2.4.4 Water Trap Installtion

The glass water trap is located in the center compartment of the CM and is shipped empty. Remove it by loosening the end caps and take it out of the CM.

There will be two silicone seals, one at either end of the water trap. Set them aside until the trap is filled and replaced in the CM.

Put a small amount of quartz wool (part number 021035) in one end of the water trap (about 1 cm); do not pack it too tightly. Fill the trap with Magnesium perchlorate (part number 021022), the water adsorbent, and leaving 1 cm empty on the other end. Put a 1 cm plug of quartz wool in the end of the trap to complete the trap.

Put one of the silicone seals on the bottom brass end fitting for the trap, put the trap into position and lightly tighten the end cap. Put the second silicone seal on the top brass end fitting, place it in position on top of the trap, and lightly tighten. Grasp both end caps and turn them simultaneously to completely seal the trap. Do not over tighten the end caps, they should be hand tight.

The analytical circuit of the CM is now complete; Autosampler, Combustion reactor, Water Trap, and GC column.

2.5 Switching the Combustion Module On

Turn the Power Switch located on the back of the Combustion Module to the ON position. The CM will turn on and go through its start up routine. You should hear the two fans on the back of the CM go on; check that there is air flow out of both fans.

Once the CM has completed the start up routine it is ready to set up the operational parameters.

Note: Do not set any temperatures or change any settings at this time.

You should be on the **Home page** of the CM software and the display should look like this:

L: 20 (around ambient) R: 20 (around ambient) O: 112

off

TOT: 0000

chns micro stby

All three of the main LEDS should be green. The Standby LED will be Red

Press the down arrow key on the keypad to scroll through the CM software pages and check the initial settings. If you need to modify any parameters, enter the value on the keypad and press ENTER to confirm the change. If any of the parameters are different from those below, change them.

Press the down arrow key:

LEFT FURNACE

[RANGE: 500-1100 C]

WORK TEMP <0000>

Press the down arrow key again:

RIGHT FURNACE

[RANGE: 500-800 C]

WORK TEMP <0000> (the right furnace is not installed in the CM, so this setting will always be "000")

Press the down arrow key again:

COLUMN OVEN

[RANGE: 30-110 C]

WORK TEMP <075> set to 75 (it does not matter what temperature is set as long as it is within the RANGE parameters, there is no GC oven installed in the CM)

Press the down arrow key again:

Sample Delay: <18 Sec> *CM setting

Sample Stop: <10 Sec> *CM setting

Oxygen Stop: <50 Sec> *CM setting

Run Time: <400 Sec> *CM setting

Press the down arrow key again:

0000cc/' **MAINS:** (reads the mains voltage coming to the CM)
 INTERNAL_T: (reads the temperature of the Main Board)
 DETECTOR_T: (no detector is installed in the CM)
 TRANSFORMER_T: (reads the temperature of the CM power transformer)

Press the down arrow key again:

Note: This page has controls for the Zero Blank autosampler (not used on the CM) and the ON/OFF switch for the column oven.

	1:	2:	3:		
AUTOS.	50	32	100	<1>	N/A
AUTOS.	PN /	EL		<1>	*CM setting
OVEN:	OFF /	ON		<2>	*CM setting

Press the down arrow key again:

Note: This page has controls for the Zero Blank autosampler; not used with the CM. These settings are not applicable to the CM.

EL. AUTOSAMPLER

GO <:>
Jog+ <:>
Jog- <:>

Press the down arrow key again and you will be back at the Home page:

L: 20 (around ambient) R: 20 (around ambient) O: 112
off

TOT: 0000
chns micro stby

You can return to the Home page at any time by pressing the **HOME** key in the center of the keypad.

2.6 Turn On the Gases

Open the gas cylinders and adjust the delivery pressures to the CM as follows:

N2 Carrier Gas:	40 psi
Oxygen:	30 psi
Air:	40 psi

On the Combustion Module:

Set the Carrier Gas pressure regulator to about 1.0 bar

Set the Oxygen pressure regulator to 1.0 bar

Set the Air regulator to 2.5 bar

Note: when you turn on the Air flow to the CM you will hear the autosampler piston move, this is normal. It is shipped with the piston in the forward position and when air pressure is applied it moves backward.

The N2 Carrier Gas is now flowing through the complete analytical circuit of the CM, Oxygen is flowing through the O2 circuit, and the Air pressure is being applied to move the autosampler.

2.6.1 Leak Testing

Leak Test Procedure:

Leave the brass plug in the port on the right side of the CM marked CRDS. Check to see that it is tight using an 8 mm wrench. That is the end of the analytical circuit and the plug is needed to perform a static leak check on the system.

If the system is leak tight and is pressurized to 1bar and we turn the Carrier Gas regulator counterclockwise (as if turning it down), the pressure on the gauge for the Carrier Gas regulator (on the CM) should remain at 1 bar.

On the keypad of the CM press the **F3** key to turn on the gases. Since the CM is currently in the Standby condition the gases must be turned on to perform the leak check. F3 will toggle the gases in and out of the standby condition regardless of the CM temperature. **NOTE: The leak test cannot be performed while the gases are in standby.**

With the pressure on the Carrier Gas regulator of the CM set to 1 bar and the brass plug in the port labeled CRDS, turn the Carrier Gas regulator of the CM counterclockwise until it is completely loose. Watch the carrier gas gauge and see if the pressure remains stable. If the gauge remains at 1 bar for 45-60 seconds the system is tight enough to operate. You may see the gauge drop slightly when the regulator is loosened, but if it remains steady then it is OK. If it falls continuously then there is a leak in the analytical circuit which must be found and corrected.

If the CM passes the leak test, turn the carrier gas regulator clockwise until you see the gauge move slightly. That indicates there is positive pressure from the regulator and gauge to the rest of the system. You can now remove the brass plug from the port labeled CRDS.

Note: Adjust the Carrier gas regulator down until there is about 0.2 bar of pressure on the gauge. This will be close to the operational setting. You will make the final carrier flow adjustment when the CM is near to the full operating temperature.

2.7 Setting the Operational Parameters and Gas Flow Rates

At this point the installation of the system is complete except for setting the operating parameters. With rare exception all samples run through the Combustion Module are analyzed under the same analytical conditions. It is rare to have to modify the parameters once the system is set up and running.

You have already set the gas pressures on the cylinders and some on the CM itself. In the final steps of the installation you will complete these gas settings and set the parameters for the combustion analysis on the CM. **Once you enter the new values on the keypad do not forget to press the ENTER key to confirm the changes. If you do not confirm the values they will revert to the previously stored values.**

1) Go back through the software pages and set the Working Temperature for the Left Furnace as follows. The other settings can be left as is.

Left Furnace: 980 C

Press the WORK Key then ENTER on the keypad to bring the CM to the working condition. This brings the temperature of the furnace and the gases to the WORKING condition. The furnace temp will climb to the set point 980 C, the carrier gas will operate at full flow, the oxygen flow is turned on, and the purge flow to the autosampler is turned on.

2) To set the Carrier Gas flow rate put one of the gas outlet fittings (part number 080020) included in the installation kit into the port labeled CRDS. That port is the end of the analytical circuit of the CM. This fitting is a tube type fitting and will be used to measure the Carrier Gas (N₂) flow rate as it exits the CM prior to being sent to the Liaison Interface and CRDS using a Bubble Flow Meter (part number 080028). Assemble the bubble flow meter by attaching the bulb and short length of tubing to the side stem. Make a small amount of a soap solution (water plus a couple of drops of liquid soap) and pour a small amount into the glass tube of the flow meter into the bulb. The soap solution will be used to create a bubble which will move up the flow meter, which is a calibrated tube (10, 20, 30... ml) and you can measure the rate of travel up the tube. For example; if the bubble travels 20 ml in exactly 12 seconds that equals a flow rate of 100 ml/min (5 x 20 ml = 100 ml, 5 x 12 seconds = 60 seconds). A flow rate of 90 ml/min would be 30 ml of bubble travel in 20 seconds.

Setting the Carrier Flow rate

Note: Wait until the temperature of the furnace is at least 800 degrees before setting the Carrier Gas flow rate. The flow rate will change as the gas viscosity changes due to the increase in temperature.

- 1) The pressure of the carrier gas regulator on the CM is now set to about 0.2 bar. Measure the N₂ carrier gas flow rate at the CRDS port and adjust the Carrier Gas regulator to get 90 ml/min of flow. As you increase the pressure the carrier flow will increase, reducing the pressure decrease the flow rate

Setting the Oxygen Flow rate

To set the Oxygen flow rate put one of the gas outlet fittings (part number 080020) included in the installation kit into the port labeled V O₂. This is the exit of the Oxygen system. Connect the bubble flow meter to the fitting.

The oxygen flow is set differently than the carrier gas flow. In the case of the oxygen we set a pressure on the O₂ regulator of the CM then use the O₂ flow valve (a needle type valve) to set the actual flow rate. The pressure of the O₂ regulator should be set to 1 bar as described earlier.

- 1) **Gently!** Close the O₂ Flow valve most, or all, of the way. Once you feel any resistance stop. Needle valves can be damaged by applying excessive pressure. You do not need to completely stop any flow from the vent, but you must start with the valve in a mostly closed position.
- 2) Check that the pressure of the O₂ regulator is still at 1 bar.
- 3) Open the O₂ Flow valve until you achieve approximately 30 ml/min. It is not critical to have exactly 30 ml/min, but it should be near to that flow rate.

Setting the Autosampler Purge Flow rate

To prevent external N₂ from the atmosphere interfering with the isotopic carbon analysis the sample is purged with N₂ gas before entering the system. This flow enters the autosampler through the port in the bottom of the autosampler and is measured at the Teflon purge line. You have already connected the purge line to the instrument and will now set the purge flow and connect the end of the purge line to the autosampler.

- 1) Attach the bubble flow meter to the purge line (slide the clear tubing over the ferrule on the end of the Teflon purge line).
- 2) Apply pressure to the Purge regulator of the CM until a flow rate of approximately 100 ml/min is achieved. This would mean a flow of 20 ml in 12 seconds.

When the correct purge flow has been set remove the bubble flow meter and connect the purge line to the port in the bottom of the autosampler. **Be careful not to cross thread the nut.** It is a fine machine thread and when it is aligned properly you should be able to hand tighten it all the way in until it stops. Use an 8 mm wrench to securely tighten it in the port. Do not tighten too much as you could collapse the end of the Teflon tubing.

The installation of the Combustion Module is now complete. Refer to the Manual for the Liaison and CRDS to complete the connection to the CM-CRDS installation and begin the analysis.

3. BASE UNIT DESCRIPTION

3.1 FRONT VIEW

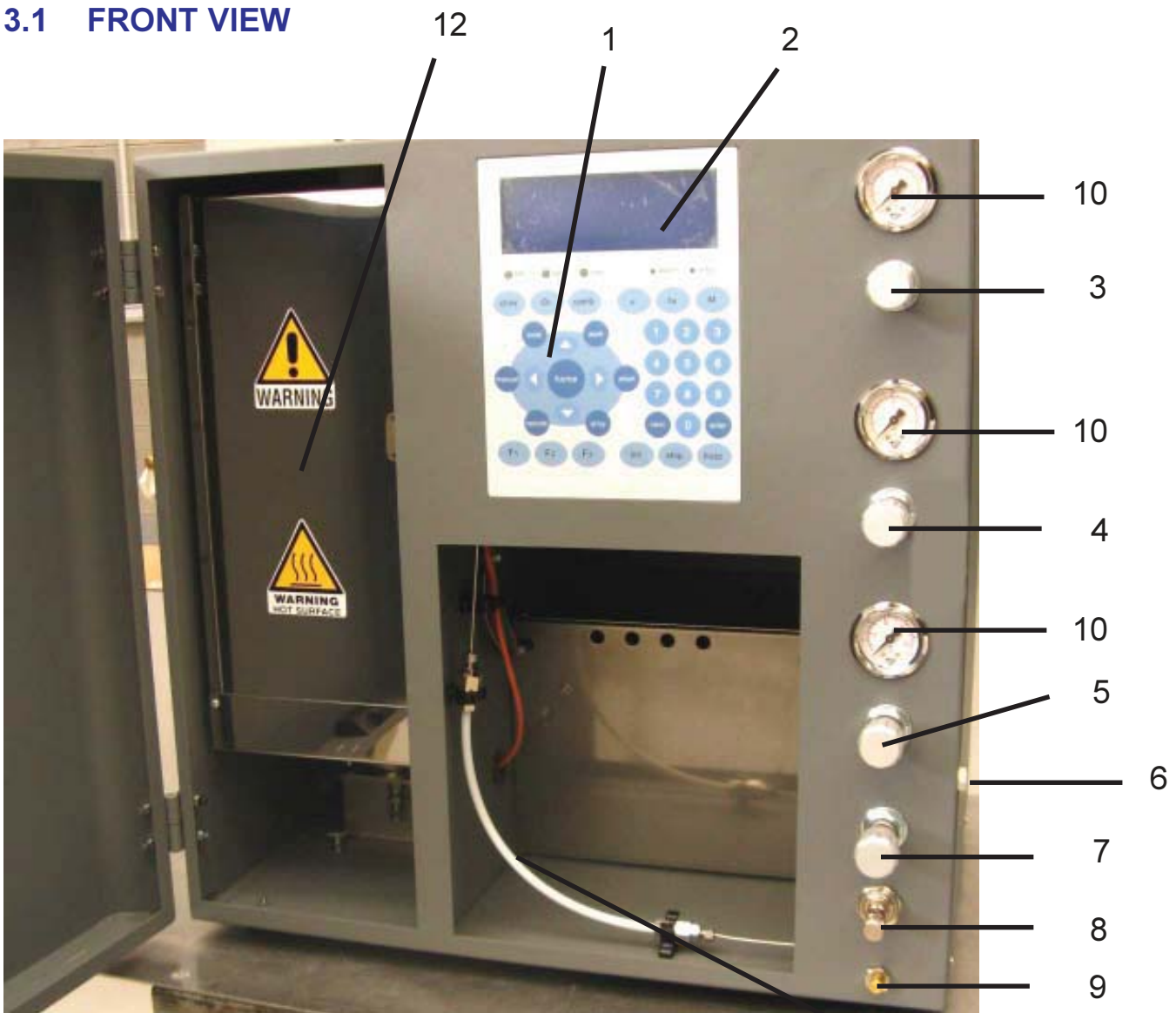

- 1. Keyboard
- 2. LCD Display
- 3. Carrier gas Regulator
- 4. Oxygen Regulator
- 5. Air Regulator
- 6. Carrier gas Vent to CRDS
- 7. Purge regulator
- 8. Oxygen Flow Valve
- 9. Oxygen Vent
- 10. Gauges for Carrier gas, O₂, Air
- 11. GC Column
- 12. Furnace cabinet

3.2 Gas Control Panel

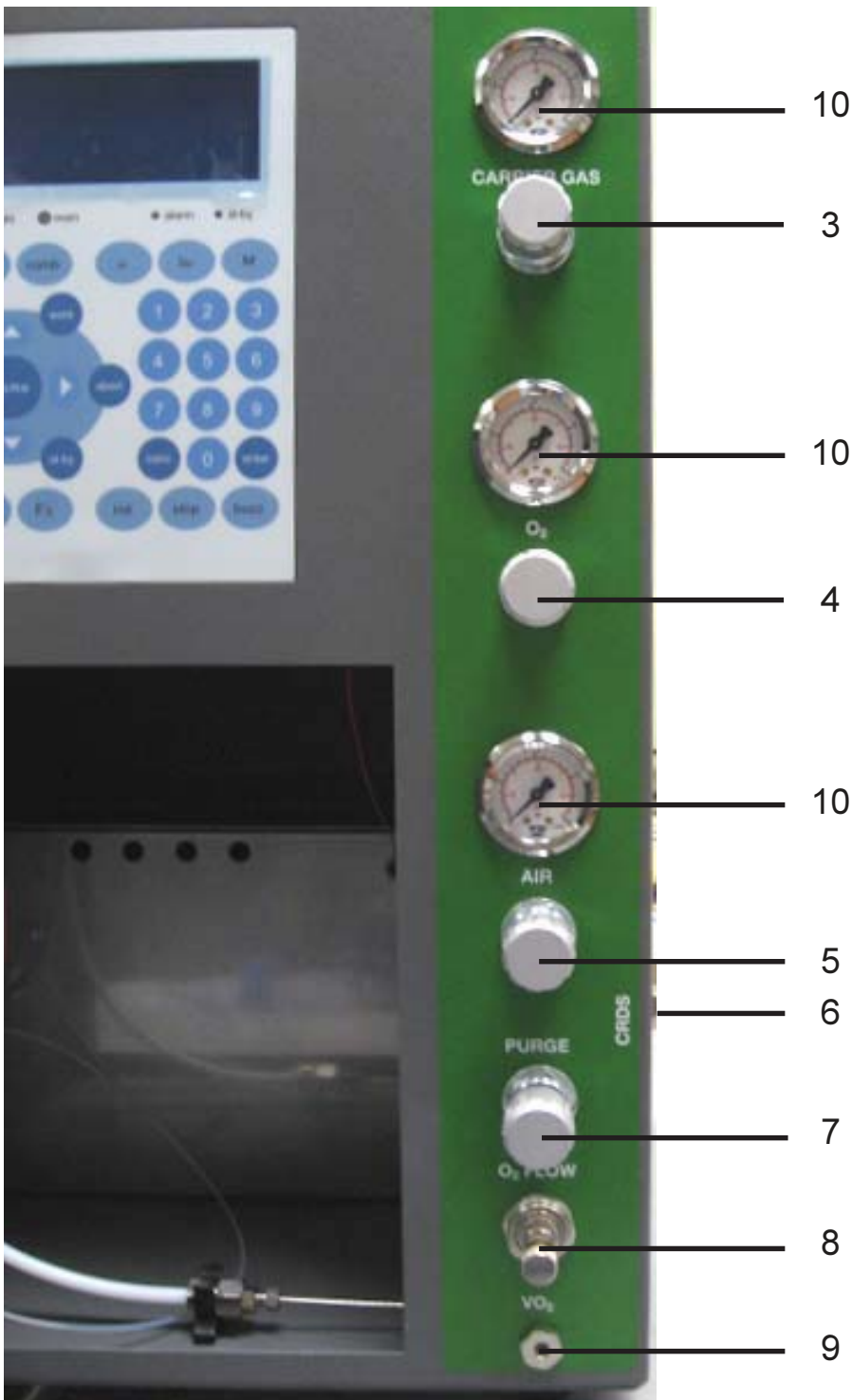

- 3. Carrier gas Regulator
- 4. Oxygen Regulator
- 5. Air Regulator
- 6. Carrier gas Vent to CRDS
- 7. Purge regulator
- 8. Oxygen Flow Valve
- 9. Oxygen Vent
- 10. Gauges for Carrier gas, O₂, Air

3.3 Rear View

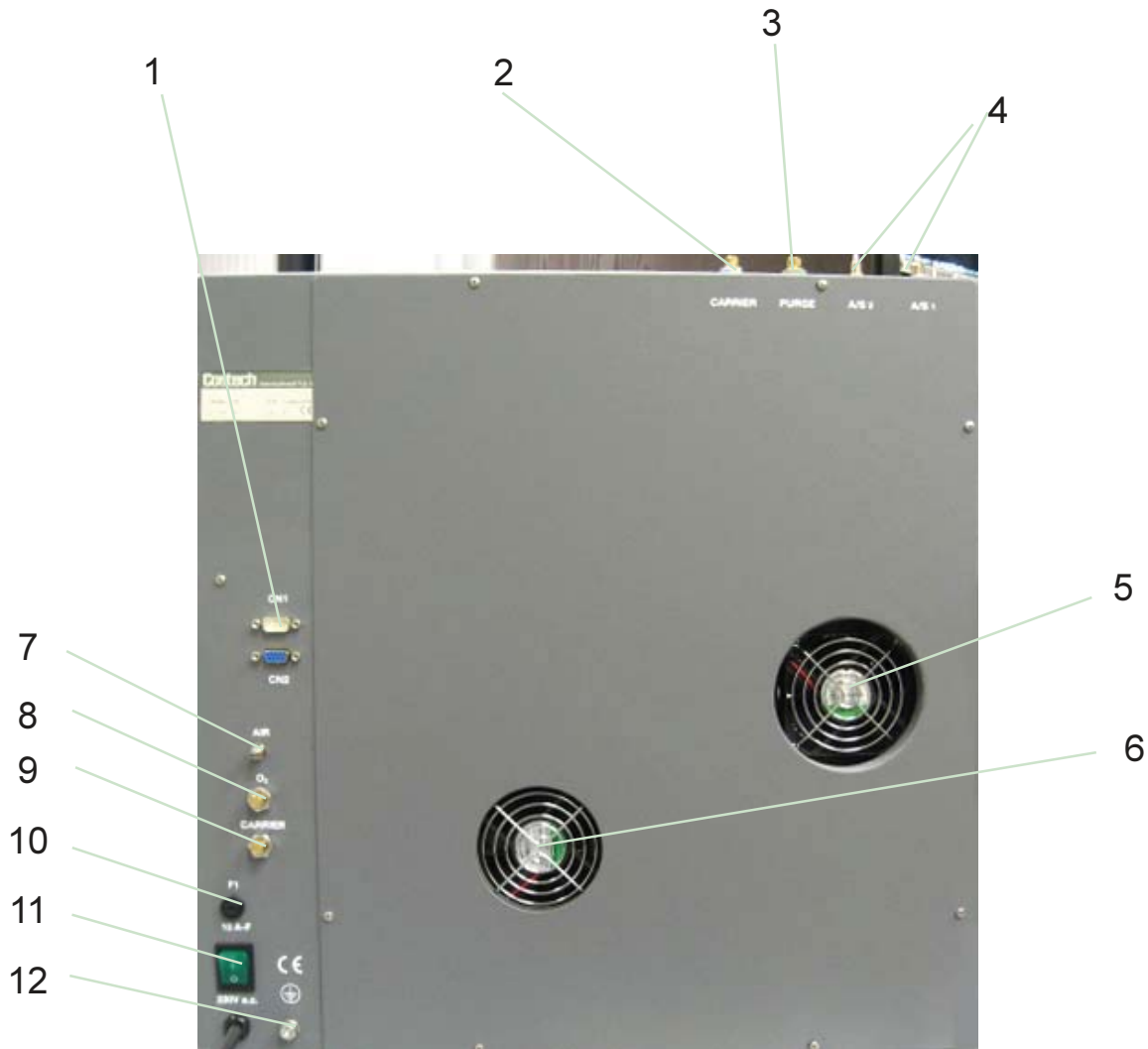

1. Connector CN1 - Start/Stop
2. Carrier gas bulkhead fitting
3. Purge line bulkhead fitting
4. Connections for autosampler pneumatic gas
5. Cooling fan for furnaces
6. Cooling fan for power supply
7. Pneumatic gas inlet
8. Oxygen inlet
9. inlet
10. Fuse
11. On/Off Switch
12. Grounding Post

3.4 Furnace

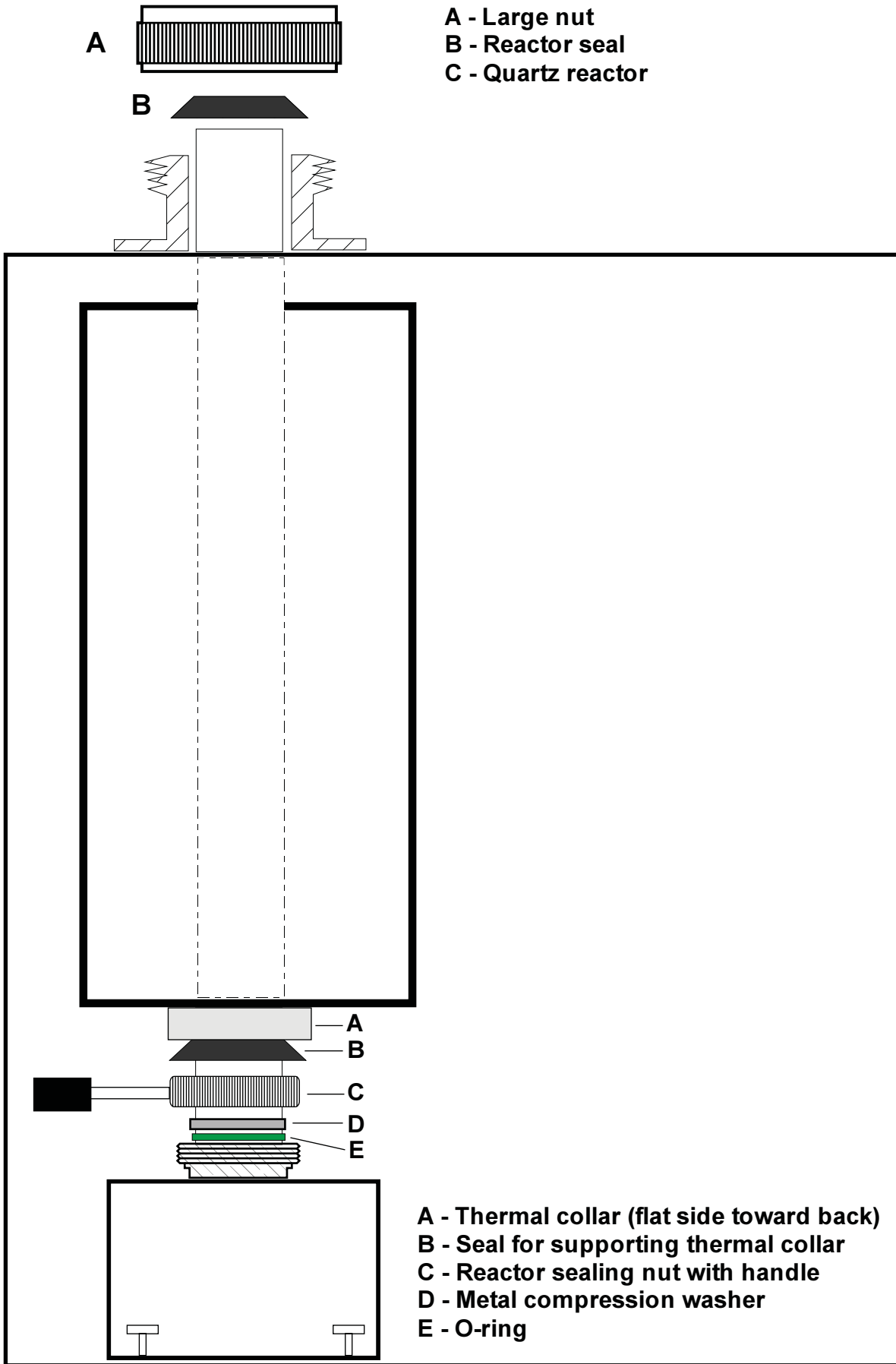

3.5 Water Trap

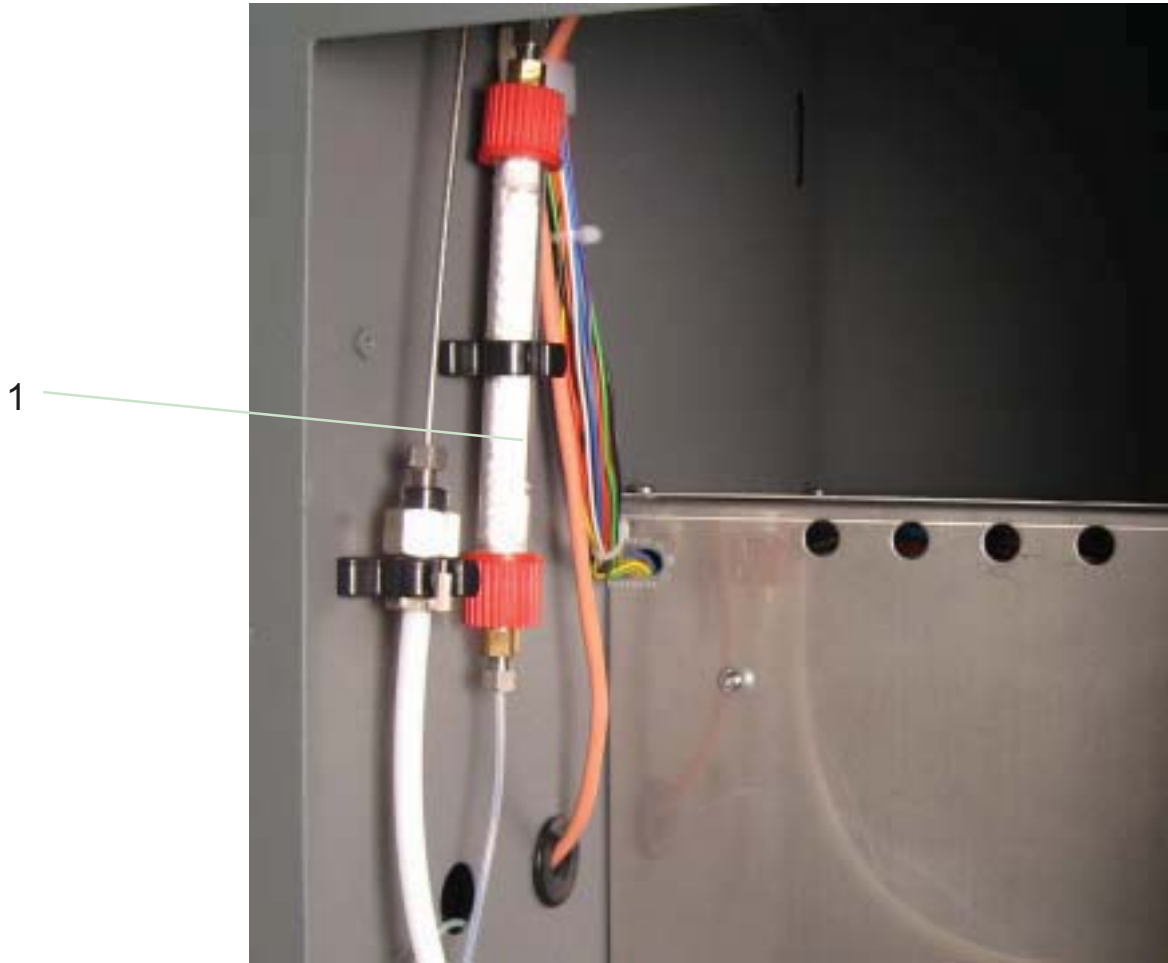

1. Water Trap

The water trap is packed with anhydrous magnesium perchlorate and adsorbs water produced by the sample combustion.

3.5 VIEW OF GC COLUMN

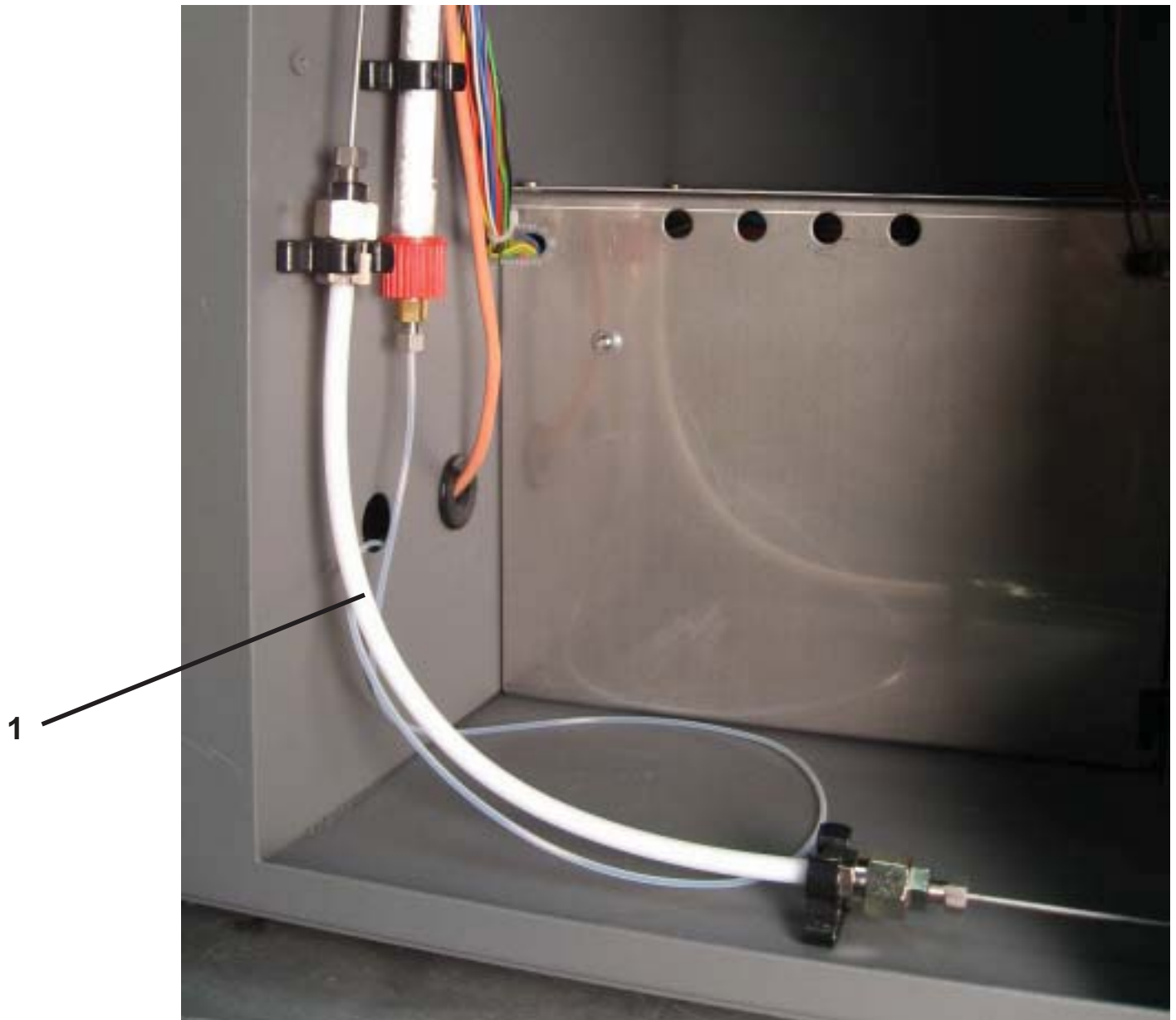

1. Short GC column

The GC column in the CM is not used for gas separation. It simply provides back pressure to the system. This is necessary for proper sample combustion.

3.6 PNEUMATIC AUTOSAMPLER

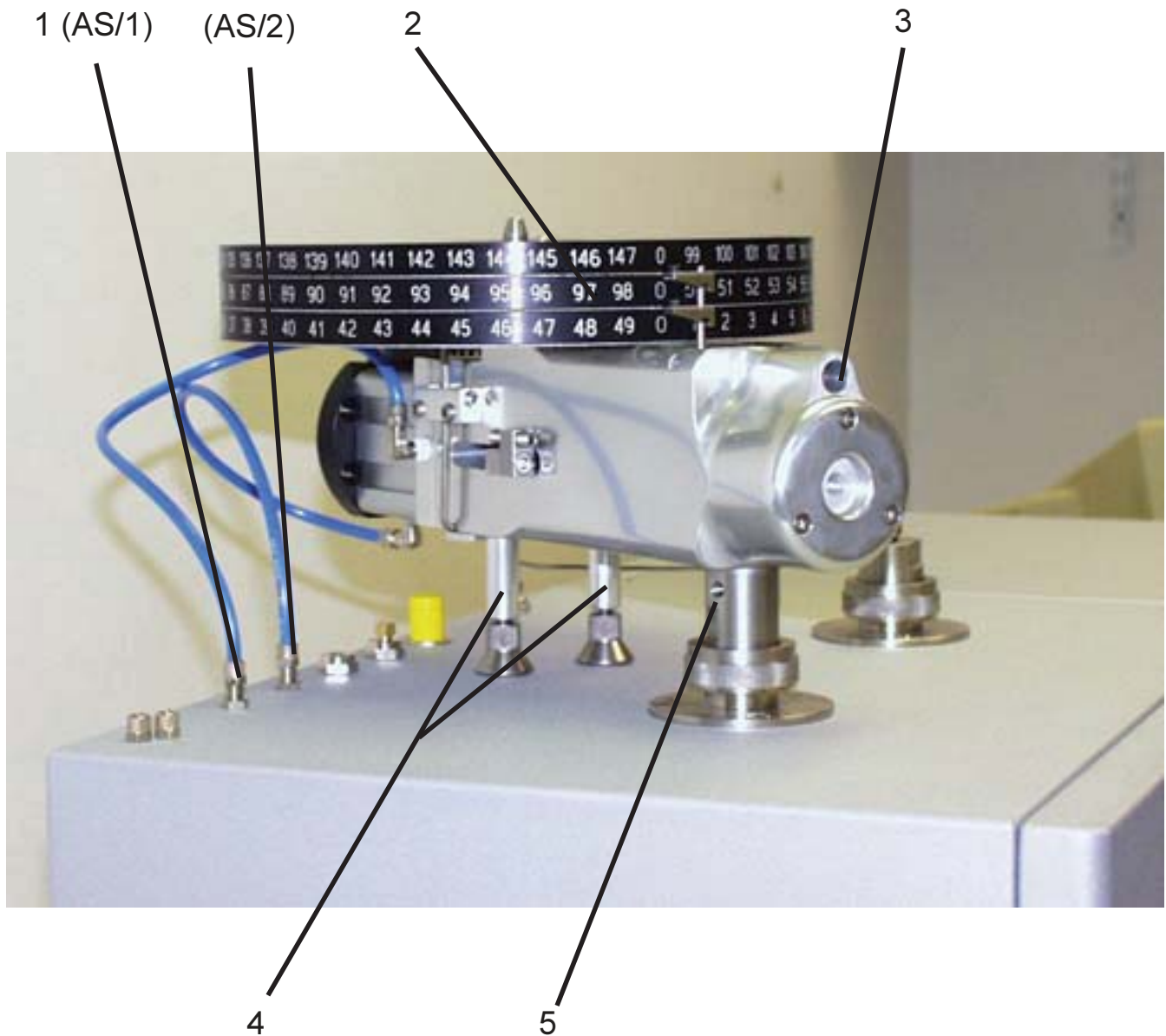

1. Air line port 1 (AS/1) connects to port in the side of the PN150 autosampler
Air line port 2 (AS/2) connects to port at the back of the PN150 autosampler
2. Sample carousels
3. Sample viewing port
4. Leveling legs
5. Carrier gas line inlet

PNEUMATIC AUTOSAMPLER PN 150

The 150 position pneumatic Autosampler (Fig. 10) has 3 trays, which are open to atmosphere and samples, can be added continuously while running. The sample holes in trays are 12 mm in diameter and can accommodate large samples. The viewing port allows the operator to see the sample combustion during analysis.

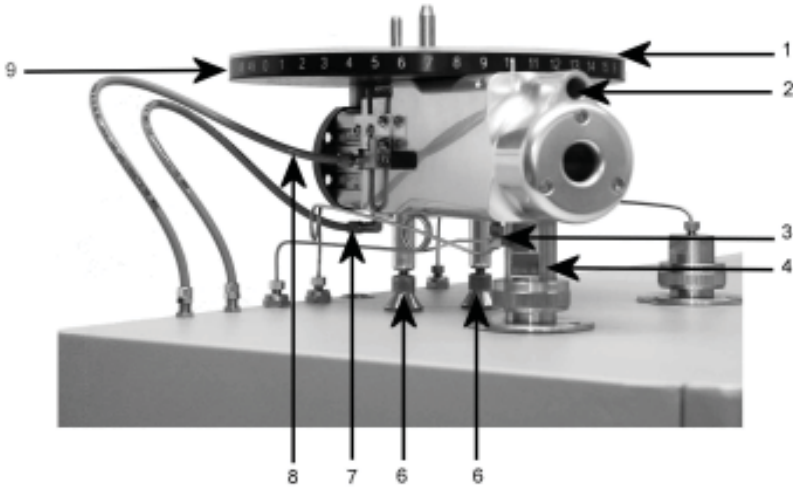

Fig. 10

1. Plastic lid
2. Viewing port (window)
3. Carrier N₂ inlet
4. Tube connecting AS with combustion reactor
5. Purge inlet
6. Levelling legs
7. Compressed air or industrial N₂ inlet - piston back (tray turns)
8. Compressed air or industrial N₂ inlet - piston forward (sample drops)
9. Tray

Fig. 11 shows the operating principle of PN 150 Autosampler

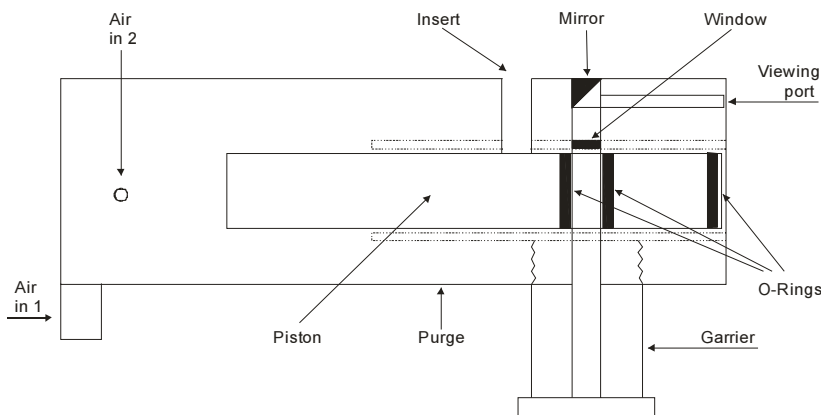

Fig. 11

In this figure the AS is in the activated position i.e. the piston has moved forward and the sample is dropped into the combustion reactor (air is switched to input 1). The operator can observe the combustion process through the viewing port. When air is switched to input 2 the piston moves back and the tray turns to the next position. The sample drops into the center hole in the piston and the cycle repeats.

3.6.1 INSTALLATION AND OPERATION INSTRUCTIONS

The carrier gas line for analytical circuit is connected to the port on the side of the tube, which connects the AS to the combustion reactor. The purge line is connected to the port on the bottom of the sampler.

Compressed air or industrial N₂ is connected to the PN150 as follows:

1. The blue pneumatic tubing is connected to the port farthest to the left on the top of the ECS 4010 and then to the side port of the PN150.
2. The second blue pneumatic tube is connected to the port second from the left on the top of the ECS 4010, and then to the back port of the PN150.
3. Compressed air or industrial N₂ pressure should be about 2.5 bars.
4. The plastic lid must always be in place on top of sample tray, to minimize the nitrogen blank.
5. The He flow rate for the purge should be set to 100 ml/min.

3.6.2 REPLACING THE MAIN PISTON O-RINGS

To replace the main piston o-rings:

1. Reverse the “Blue” pneumatic tubing so the piston slides completely forward
2. Pull the Main Pin from the left side of the Autosampler.
3. Remove the round front plate of the sampler, exposing the end of main piston.
4. Screw in the special cone-shaped tool so the narrow end is towards the piston and pull the piston out of the Autosampler. NOTE: If you do not have the tool, use a ¼ -20 bolt to pull out the piston. You can also microwave the o-rings in water for 1-2 minutes to soften them up, this will make them easier to install on the piston.
5. Reverse the tool so the larger end is towards the piston. Use it to slide the o-rings onto the piston (o-rings made of a carboxylated nitride compound).
6. Lubricate the o-rings with a tiny amount of silicon based vacuum grease. Be careful not to get any into the center hole, as the samples will stick to it. Clean any excess off of the main piston.
7. Reverse the tool again and replace the main Piston in the Autosampler. When the piston is all the way in, turn it so the square hole in the main piston lines up with the hole in the air cylinder piston and re-insert the main pin.
8. Reverse the “Blue” pneumatic tubing so they are in their normal operating positions.
9. Run a couple of blanks to check the new o-rings.

3.7 PNEUMATIC SECTION

3.7.1 PHOTO OF PNEUMATIC SECTION

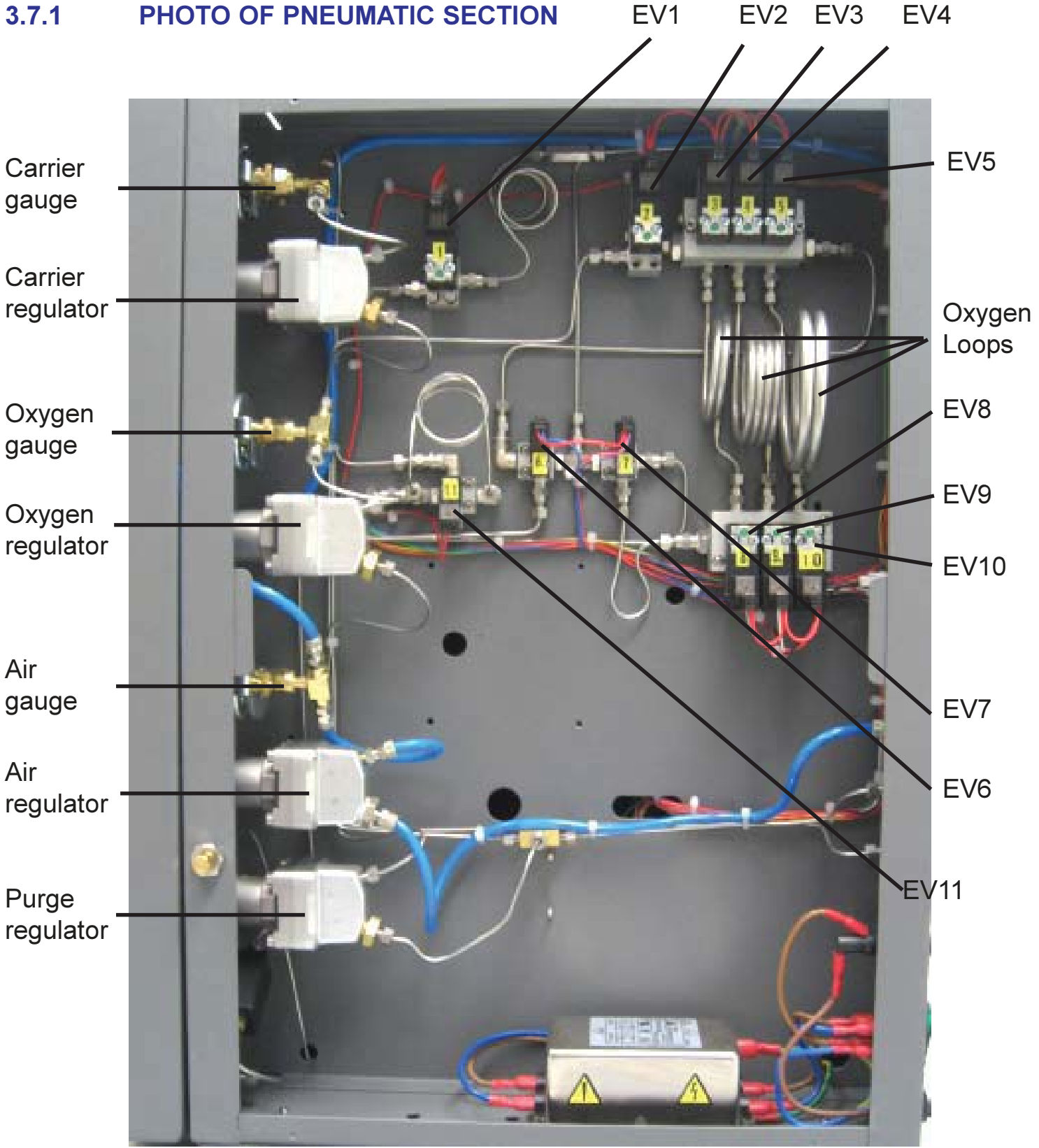

3.7.2 PNEUMATIC TOPOGRAPHIC DIAGRAM

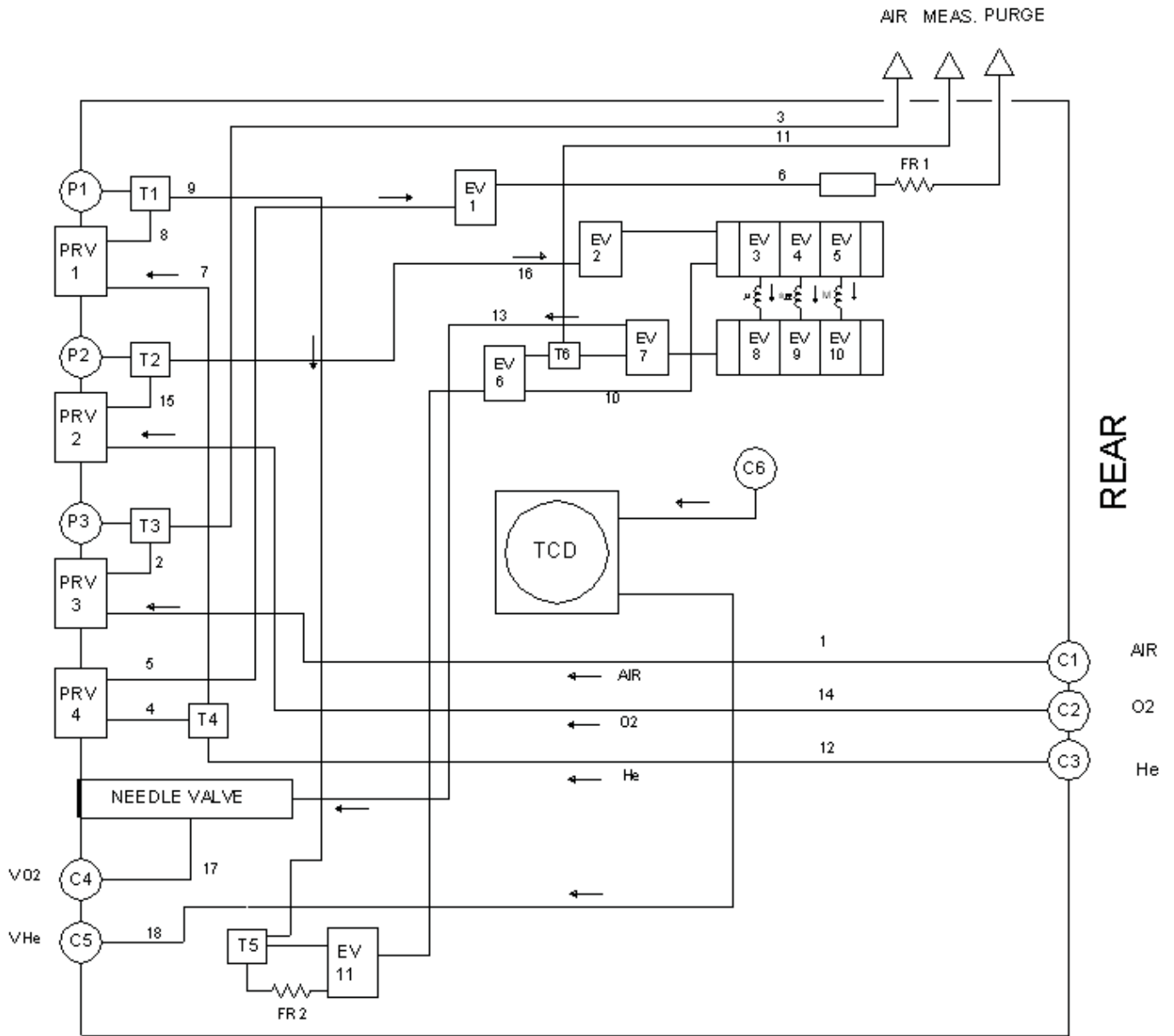

PICARRO

4.1 KEYBOARD

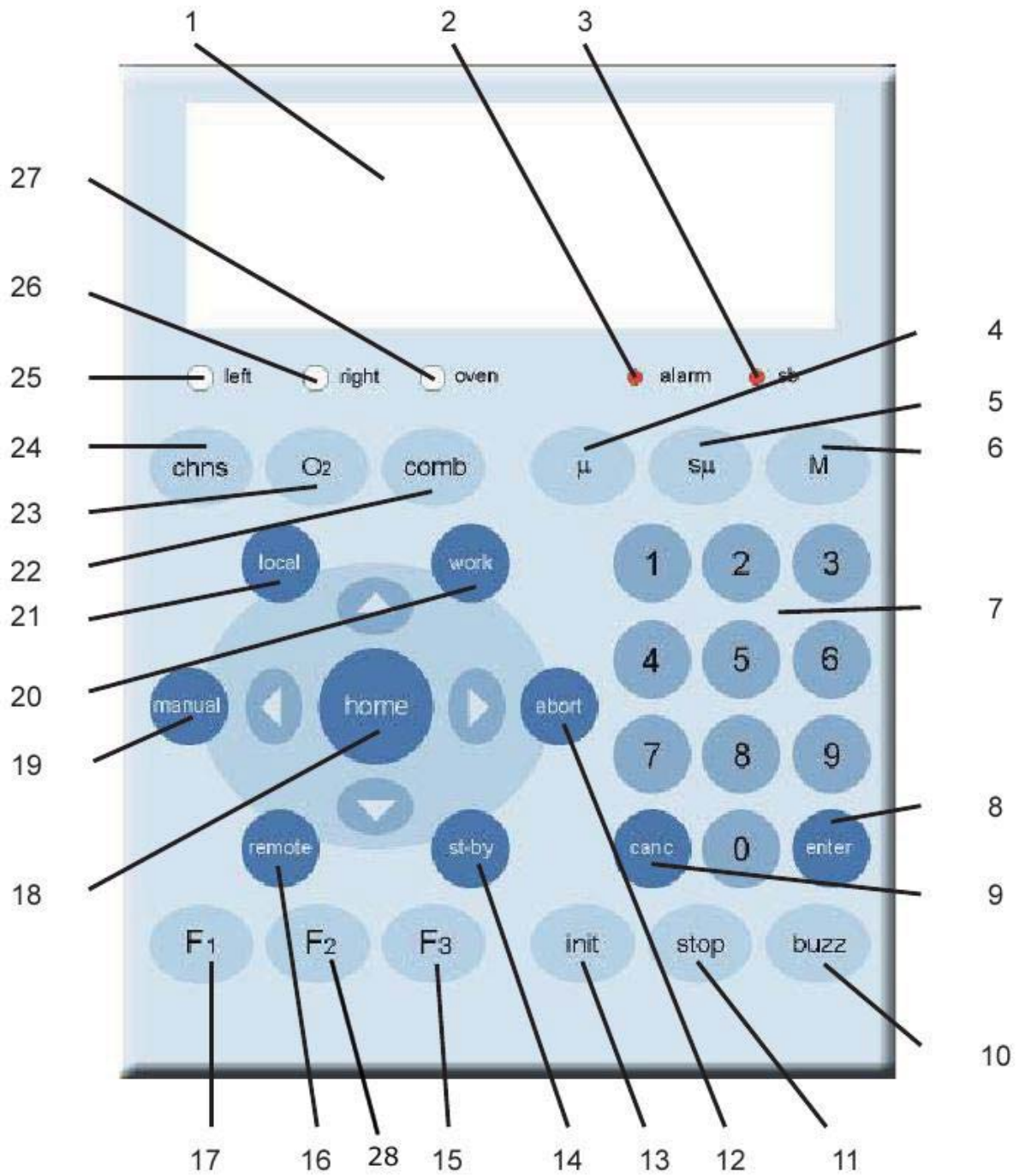

4.1.1 KEYBOARD DESCRIPTION

1. LCD Display Screen
2. Alarm LED
3. Stand0by LED
4. Micro Oxygen Volume Select
5. Semi-micro oxygen Volume Select
6. Macro Oxygen Volume Select (No Current Function)
7. Numeric Keypad
8. Enter Key
9. Cancel Key
10. Buzz Key
11. Stop Key
12. Abort Key
13. Initialize Key
14. Stand-by Key
15. F3 Key
16. Remote Key
17. F1 Key
18. Home Key
19. Manual Key
20. Work Key
21. Local Key
22. Combustion Key (No Current Function)
23. O2 key
24. CHNS Key
25. Left furnace LED
26. Right Furnace LED (Not existent on the CM)
27. Oven LED (Not existent on the CM)
28. F2 Key

4.2 INTRODUCTION

All functions of the instrument are controlled by the “user friendly” interface which consists of the keyboard, display, and LED’s. Using the display, the operator can enter different commands or change parameters.

4.3 STARTING OFF

4.3.1 STEP 1: POWER ON

During the “Start Procedure,” the memory of the CM is initialized, all information from the EEPROM is read, and a soft start of the furnaces is begun to absorb the initial surge of power from the transformer. Immediately after, the program to heat the left furnace is implemented.

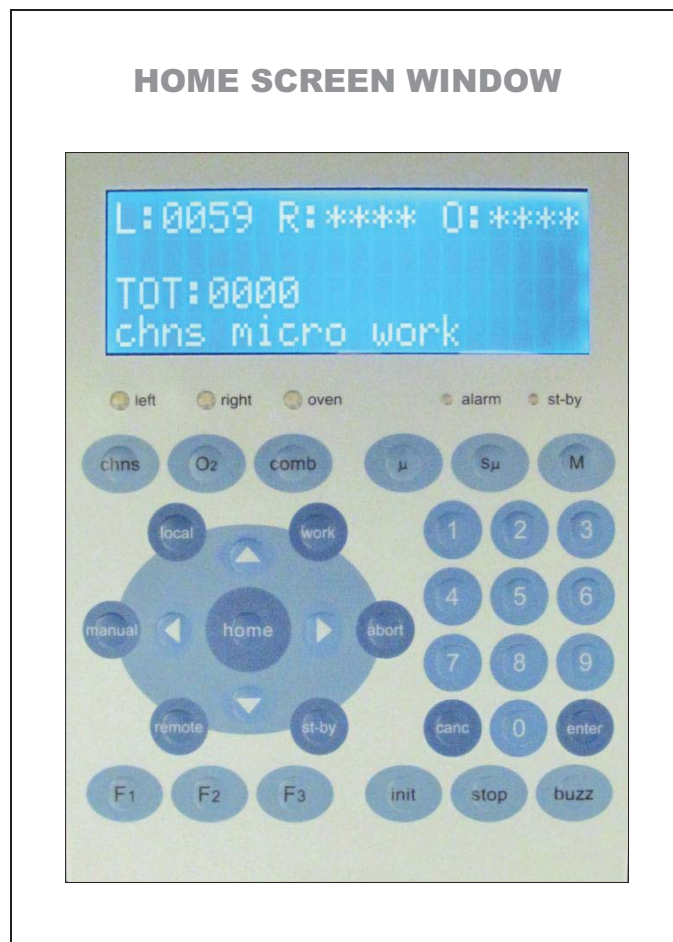

The opening display will look like the figure above. This is the “Home Screen Window.”

DEFINITIONS OF TERMS ON THIS WINDOW:

A. **L, R, O:** Temperature of the Left furnace, Right furnace, and GC Oven.

Note: The right furnace and the GC oven are not available on the CM

B. **TOT:** Number of analytical cycles completed.

C. OPERATION MODE:

i. **CHNS:** Combustion Mode or...

ii. **O₂ :** No Oxygen Injection

D. OXYGEN INJECTION VOLUME:

i. **Micro (μ)** = 2.5ml loop

ii. **Semi-Micro (Sμ)** = 5ml loop

iii. **Macro (M):** The Macro Oxygen volume option is NOT available on the CM

E. **WORK:** Signifies that the furnace and the oven are ready to begin analysis.

4.3.2 STEP 2: Going to the Main Menu.

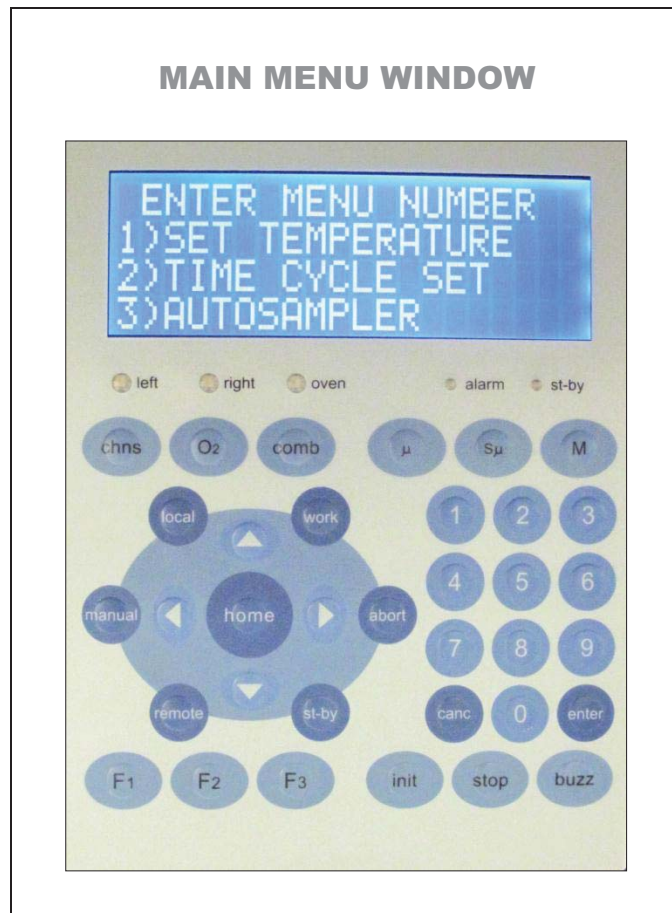

When you press “F2” from the Home Screen Window, the following will be displayed on the LCD. This is the “Main Menu Window”.

You can press “1”, “2”, or “3”, to set the Temperature, the Time Cycle Set, or the Autosampler Type accordingly.

4.3.3 STEP 3: SETTING THE TEMPERATURE

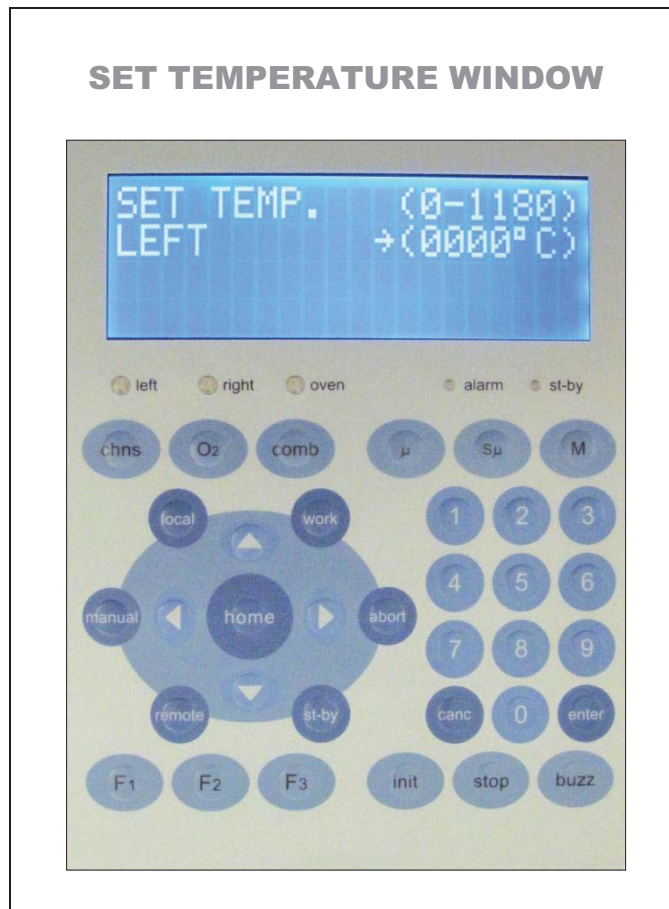

If you select “1” from the “Main Menu Window,” you will see the following displayed on the LCD. This is “the Set Temperature Window.”

The following keys are functional on this window:

- Numerical keys
- CANC to Reset the Temperature to 0 Degrees Celsius
- BUZZ to stop the audible alarm
- ENTER to “activate” the display arrow.

To set the combustion temperature, first press “enter” (The direction arrow will flash), and then enter the temperature “0980”.

Press “Canc,” to reset the temperature to 0000 degrees Celsius.

To save your parameter and to go back to the main menu window, first press “F2.”

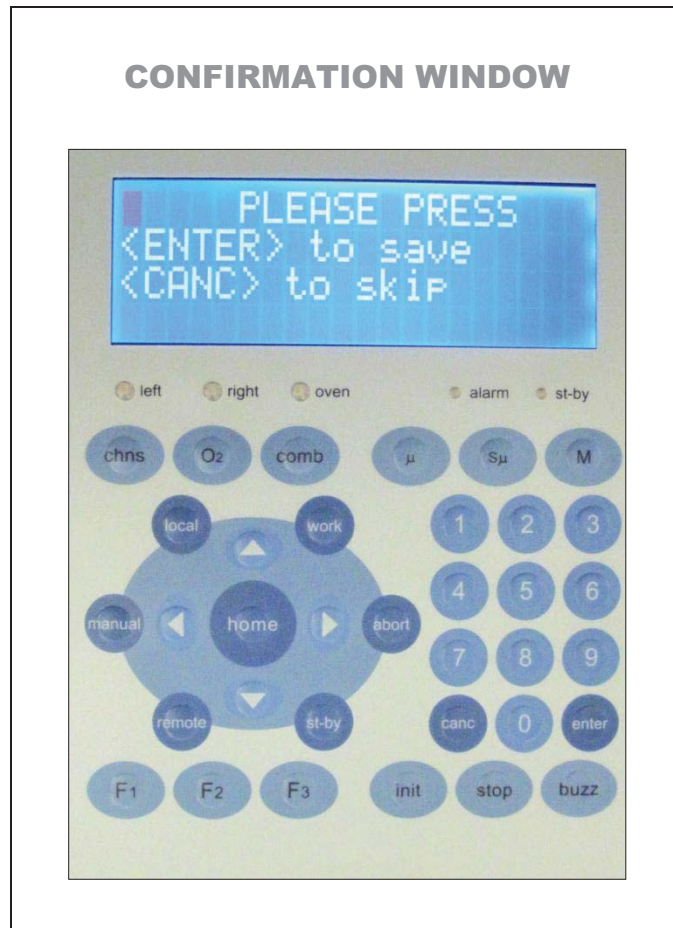

Upon pressing “F2”, you will see the following displayed on the LCD. Press “Enter” to save the new parameter.

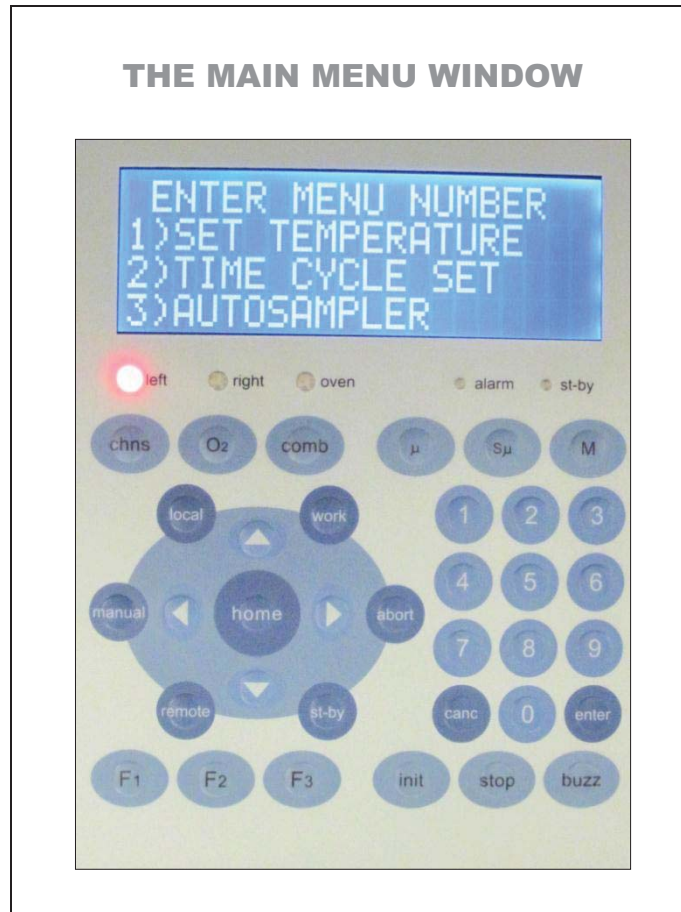

Upon saving the new temperature parameter, the left LED will flash to indicate that it is heating up.

From this “Main Menu Window,” you can go back to the “Home Screen Window” by pressing the “Home” key.

NOTE: If the input temperature is not within the allowed range, the display emits a warning “beep”, and the set point reverts to the old value. If “0000” is entered, the furnace is considered not to be in use; no power is sent to the furnace.

4.3.4 STEP 4: Setting the Time Cycle.

When you press “2” from the “Home Screen Window”, the menu below will be displayed on the LCD. This is the “Time Cycle Set Window”.

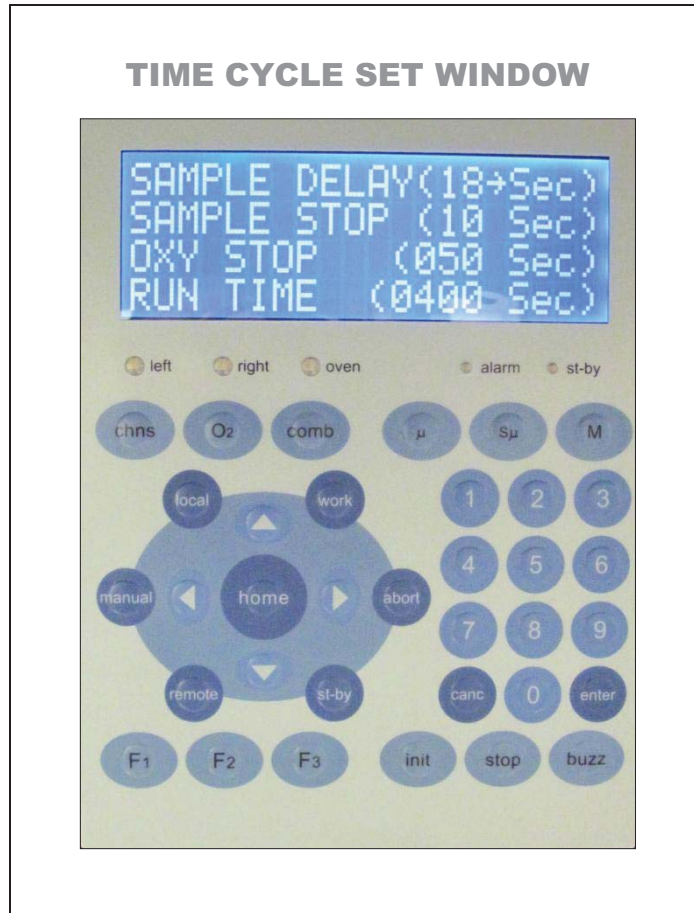

To change any of the parameters on this screen, first use the top and bottom arrow keys around the “Home” key to select the desired parameter. Afterwards, press “Enter”, (The LCD direction arrow will flash) and then type in the values accordingly using the number keys. When finished, press “F2” and then “Enter” to save your parameters and to return to the main page.

Numerical Values in the figure above are the values recommended by Picarro.

DEFINITIONS OF TERMS ON THIS WINDOW:

1. SAMPLE DELAY: Sets the delay time from the start of a cycle to the time of autosampler activation and sample drop. It must be in the range of 01-99 seconds. This delay is necessary, in the combustion (CHNS) mode, to allow time for the oxygen to arrive at the combustion reactor. The ideal situation is for the sample to drop into the combustion reactor approximately 1-2 seconds prior to the arrival of the oxygen.

2. SAMPLE STOP: Sets the time for the end of the autosampler activation. It must be greater than the Sample Start time and less than 100 seconds. This has no analytical effect, but determines the length of time combustion can be seen when using the pneumatic autosampler, and the carousel rotation to the next sample. Sufficient time from the Sample Stop time to the end of the cycle should be allowed for sample purging.

3. OXY STOP: Sets the time when the electrovalves for oxygen introduction switch and begin to re-fill the oxygen volume for the next sample.

4. RUN TIME: Sets the time from the beginning of one cycle to the end of the cycle. When programming N (number of analyses in Manual mode) cycles, this setting will control the total time of each analysis. It must be greater than OXY STOP time and less than 2000 seconds.

In Manual (N = 0 or 1) and Remote modes, a cycle is only considered to be complete at the end of the RUN TIME. The next cycle cannot be started until the end of the RUN TIME.

NOTE: If a value is entered for any of the timing functions which is out of the allowed values for the function, an audible warning is given and the previous value is re-entered.

4.3.5 STEP 5: Setting the Autosampler Mode.

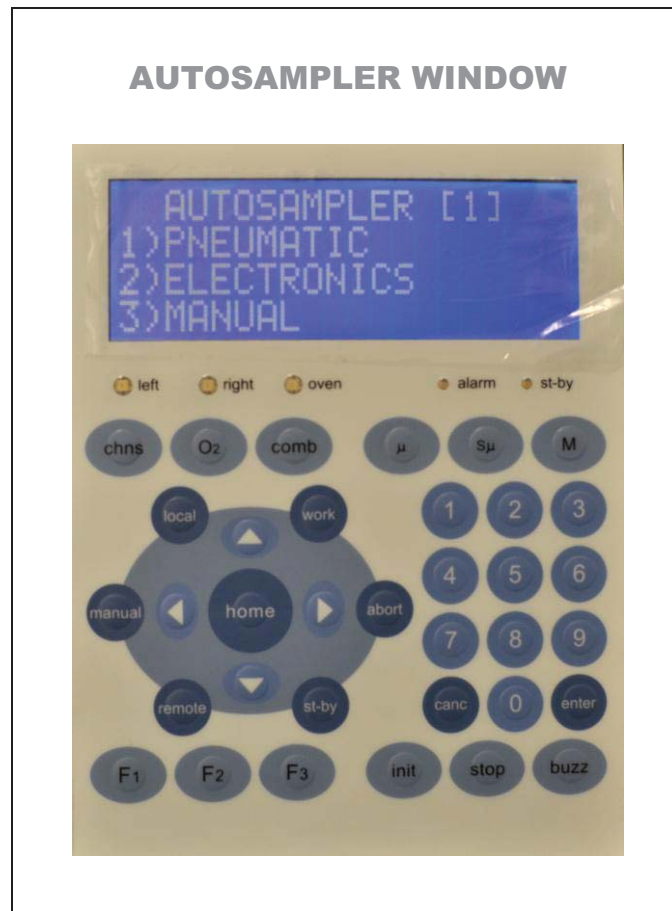

When you press “3” from the “Main Menu Window,” you will see the following LCD screen. **Please choose the “1) Pneumatic” setting for your CM** by pressing the “1” key. You will be immediately taken back to the “Main Menu Window.”

To return from the “Autosampler Window” to the “Main Menu Window”, press the “Abort” key.

The keys which function on this page are:

1. Numerical 1, 2, and 3.
2. Abort: To return to the main menu.
3. Buzz: To turn off the audible alarm.



If you press “2) Electronics,” and is directed to the “Carousel Window” (Left Window Above), you can return to the previous “Autosampler Screen Window” by pressing on the “Abort” key.

From the “Carousel Window”, if you press 1, 2 or 3 you will be directed to the “Lineup Window” shown on the right hand side above.

NOTE: The menu of the “Line Up Window” is inactive for the CM model.

4.4 Operation Key Explanations

CHNS: To select the CHNS (Combustion) analysis mode.

O₂: To select the Oxygen analysis Mode. In this mode, no O₂ will be pulsed into the reaction tube when the sample intended for analysis is dropped into the reactor.

COMB: Used for implementing special “Combustion” programs. However, **this key has no function**, currently.

μ: To select the Microanalysis Oxygen Volume (2.5 ml Loop).

Semi-μ: To Select Semi -Microanalysis Oxygen Volume (5ml Loop).

MACRO: To select Macro-analysis Oxygen Volume (**CM does not have a Macro option**).

INIT: To reset the sample cycle counter to zero.

STOP: To exit from the Manual Mode.

ABORT: To exit from the “Set Temperature Window”, “Time Cycle Set Window”, and the “Autosampler Window”.

WORK: Functions only if the analyzer is in “stand-by” condition. Pressing this key turns off the stand-by LED and brings the left furnace to its operating temperature.

ST-BY: Functions only if the analyzer is in “work” condition. Pressing the “st-by” key will lead you to a screen where you can set time (**in minutes**) until stand-by. If you set the time to 0 (min), the CM stand-by status will not occur. If you set the time to X min (X > 0), then after X-min, the temperature of the furnace will be decreased by 200 degrees below the set working temperature. The gas flows will be switched to a gas saver mode which is a dramatically reduced flow rate. The “st-by” red LED is lit to indicate Stand-by status.

NOTE: If an analysis is attempted while the CM is in St-by mode, the display shows “Not ready” and the analysis cycle will not start.

In “stand-by” condition, all electrovalves are in the non-activated position, except for EV 1 and EV 11 which are activated and shut off the “N₂ purge” (for the autosampler) and decreases the N₂ carrier gas flow (about 30 ml/min). All electrovalves for the oxygen injection (EV’s 3,4,5,8,9,10) are deactivated, shutting off the oxygen flow. “Off” is displayed on the LCD

panel.

A gases “stand-by” condition can be activated, even while the CM is in the “work” state, by pressing the **F3 key**. The N₂ purge is stopped, O₂ flow is stopped and N₂ carrier flow is decreased. Pressing the **F3 key** again cancels the gases “stand-by”.

F1: This key is active in the CHNS mode. Pressing **F1** inhibits the autosampler function. When pressed, the pneumatic autosampler will not operate. To undo the autosampler function inhibition, press the **F1 key** again.

F2: From the “Home Screen Window”, “Time Cycle Set Window”, or the “Set Temperature Window”, you can get to the “Main Menu Window” by pressing the **F2 key**.

F3: Pressing F3 activates the gases stand-by condition, and “Off” is displayed on the LCD. The gases stand-by state can be activated, even while the CM is in the Work state, by pressing the F3 key. The N₂ purge is stopped, O₂ flow is stopped and N₂ carrier flow is decreased. Pressing the F3 key again cancels the “gases stand-by”. The analysis cycle cannot be started while F3 is activated.

ENTER: To confirm a menu choice

BUZZ: Pressing this key silences the alarm

MANUAL/LOCAL: Manual mode allows you to run a pre-set number of analyses. After pressing the key, the CM asks for the number of cycles to be run. Enter a number from 01-99 cycles, and confirm your choice by pressing Enter. The first cycle will start only after the left furnace reaches the “Work” temperature; otherwise, the “Not Ready” message is displayed.

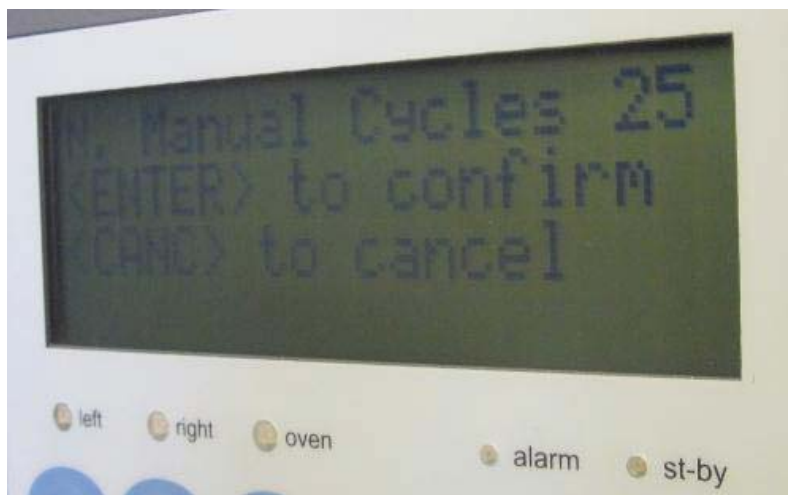

(The LCD screen above shows that 25 analyses has been entered)

During the execution of the analytical cycles, “RUNNING” is displayed on the “Home Screen Window”, as well as the total number of samples run.

You can program the number of cycles to be run before the CM has reached the temperature set points (“work” state). This mode can be used to run a number of bypass samples (samples used to “condition” the CM prior to analyzing standards and unknown samples). After switching the CM from “Stand-by” to “Work”, load them in the autosampler, program the number of bypass cycles in the Manual mode and press “Enter”. The cycles will start when the CM reaches operating temperature.

If you need to interrupt the sequence, press “Stop”. If a cycle has started “Wait” will be displayed until the Sample Stop time has been reached, then “End of Cycle” is displayed. To reset the display press “Home”.

If the temperature goes out of ready condition during a cycle, the analyses are halted and the “Not Ready” status appears in the display. When the temperature returns to “Ready”, the cycles will automatically restart.

During the cycle, no changes can be made to the instrument parameters.

To exit from “Manual” mode and cancel the pre-set number of samples, press “STOP”.

REMOTE: Remote mode transfers control of the start/stop function to an external device, such as the Picarro Liaison Interface or the Picarro CRDS.

When Remote is pressed, the CM asks for confirmation. Pressing “Enter” puts the CM into “Remote” mode. If the CM has not reached the operating temperature (Work State), both “Remote” and “Not Ready” are displayed, and the CM will wait until the temperature set point is reached. An internal signal is then sent, which enables the external device to start the analysis cycles.

To exist from Remote mode, press the “Local” key and then the “Enter” key to confirm.

While in remote mode, “REM” is displayed as well as the total number of cycles on the “Home Screen Window”. At the end of every cycle, “End of Cycle” is displayed, the sample counter incremented by 1, and the signal enabling the remote start is reactivated.

PICARRO

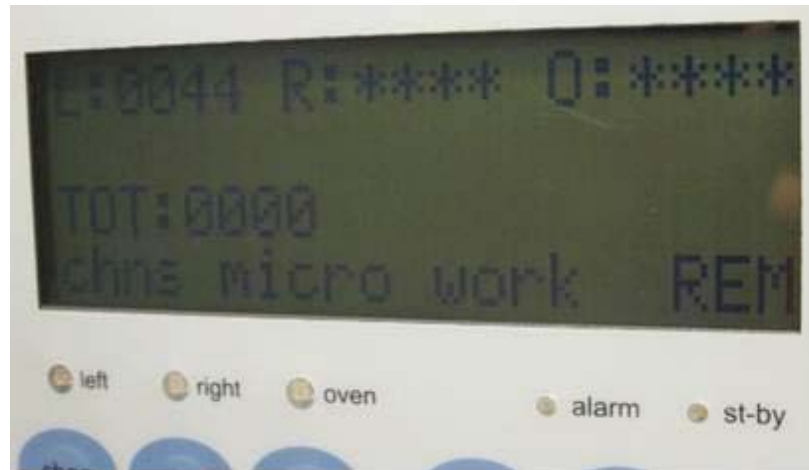

When the external device ends the sequence of analyses, CM will remain in the remote mode until the “local” key is pressed.

Press “local” and then “enter” to confirm to interrupt the remote sequence. If a cycle is in progress, it will finish, and “stopped” is displayed. When stopped, the CM will not accept a start signal from the external device. To restart remote mode, press “Stop” again.

To exit from Remote mode without signal from the external device, press “local” and then “Enter” to confirm. If a cycle is in progress, “Wait” is displayed until the cycle is finished.

When in “remote” mode, all the “Local” menus are unavailable, and no changes can be made to instrument parameters.

4.5 Alarms and Warnings

The Combustion Module has three types of alarms and warnings:

1. Warnings, which are only an indication of temperature variations outside the pre-set ranges.
2. Alarms which do not allow an analysis to be run.
3. Alarms which switch off power to the furnaces and block all instrument functions until reset.

1) Warnings (Low Level)

ALL INT-T: Internal temperature $>45^{\circ}\text{C}$; it will stop as Internal Temperature drops below 40°C .

ALL TRANS -T: Temperature of the transformer $>60^{\circ}\text{C}$; it will stop as temperature drops below 55°C .

ALL DET-T: Detector temperature (+/-) 0.2°C ; it appears only during an analysis cycle, it will stop if during an analysis there is no detector temperature change.

AC MAINS: Power less than 200V; it will stop when the power is $>215\text{V}$.

POWER OFF: This warning appears on page 1 (Home Page), if a power failure occurs while the analyzer is running in LOCAL or REMOTE modes. When main power is restored, the analyzer will return to the Standby conditions.

NOTE: If the analyzer is switched off while in LOCAL or REMOTE modes, when power is turned back on, the display will show the “Power Off” alarm.

Pressing “Home” removes the warning from the display.

When a warning (type A) appears, the LED “alarm” is lit and the audible alarm sounds (it can be turned off by pressing the “Buzz” button). To determine what caused the alarm, press either the left or right arrow

key. None of these warnings influences the regular analysis functions of the CM.

2) Warnings which stop analyses.

It is impossible to begin an analysis cycle if the left furnace is not at the set “Work” temperature.

When at the set “Work” temperature, the furnace is allowed a (+/-) 6°C temperature variation. If the temperature goes out of this allowable range, the analysis cycle will not start.

T LEFT: If the temperature of the left furnace varies by (+/-) 20°C. This alarm disappears when the temperature is less than (+/-) 18°C of the set point.

When this alarm is activated, the “Alarm” LED is lit and the audible alarm will sound. The audible alarm can be turned off by pressing the “Buzz” button.

After the condition which caused the alarm is corrected, the analysis will continue from the point of interruption.

3) Alarms which switch off power to Furnace and block all instrument functions.

ALL EEPROM: This alarm can only appear during the initial power up of the analyzer. It indicates that there is no communication with the non volatile memory EEPROM. The instrument functions are completely blocked and the display shows “NOT ACCESS TO EEPROM”.

THERMOCOUPLE L: KO: Indicates that no change of temperature has occurred in the left furnace in 8 minutes, whether power is applied or not. Left thermocouple, furnace resistance, or power electronics are possible sources of the problem.

NOTE: Neither a Right furnace nor a GC Oven are installed in the CM.

INTERNAL T ALARM: The internal temperature of the CM is over 50°C.

4.6 ALARM LED'S

Red LED Alarm: Indicates alarm status

Red LED Stand-by: If lit, indicates the CM has been set in “stand-by” mode. If not lit, indicates the CM has been set in “work” mode.

Left: Red LED indicates power is being applied to the furnace. Green LED indicates that the furnace has reached the set “work” temperature and has been stable for 2 minutes.

NOTE: Since **NO Right furnace and GC Oven** are installed, the LEDs for the Right and Oven will not be turned on.

5. OPERATING PRINCIPLE



During normal system operation, Nitrogen carrier gas circulates within the analytical circuit which consists of a combustion reactor, water trap and GC column. The carrier gas brings the combustion gases to the Liaison interface module and CRDS for $^{12}/^{13}\text{C}$ measurement.

Combustion Analysis

At the start of the analytical cycle the N_2 carrier gas is switched to a volume of oxygen which is chosen by the operator depending on the size and composition of the sample. The samples are dropped automatically into the combustion reactor prior to the arrival of oxygen in the combustion reactor. The sample and tin capsule react with oxygen and combust at temperatures of $1700\text{-}1800\text{ }^\circ\text{C}$ and the sample is broken down into its elemental components, N_2 , CO_2 , H_2O and SO_2 . High performance copper wires absorb the excess oxygen not used to combust the sample. Sulfur oxides are adsorbed by one of the oxidation catalysts and water is adsorbed by the material packed in the Water Trap. The gases ($\text{N}_2 + \text{CO}_2$) flow through the short gas chromatographic column and into the Liaison interface module where the gases are held in a 500 ml gas sampling bag. The gases are pumped into the isotopic CO_2 analyzer and the delta $^{13}/^{12}\text{C}$ is measured.

6.1. Packing for the Combustion/Reduction reactor

CM Single Reactor Packing Diagram

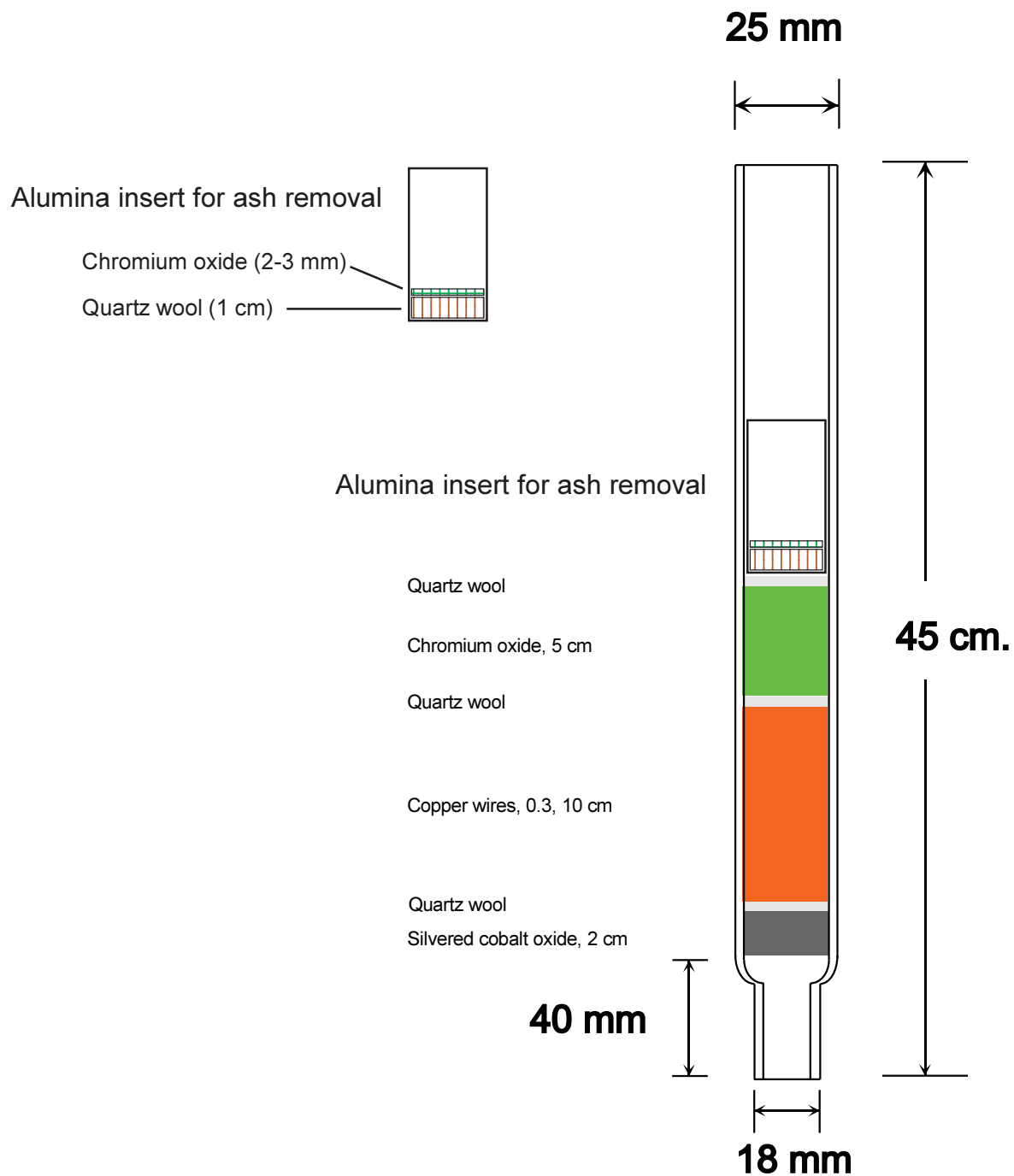

6.2

Packing the H₂O Trap - Part number 071120

- 1) Pack the outlet side with 5 mm quartz wool.
- 2) Fill the trap with magnesium perchlorate.
- 3) Pack the inlet side with 5 mm quartz wool.

Note: Gently tap the trap while packing to settle the reagent. Do not pack the trap too tightly.

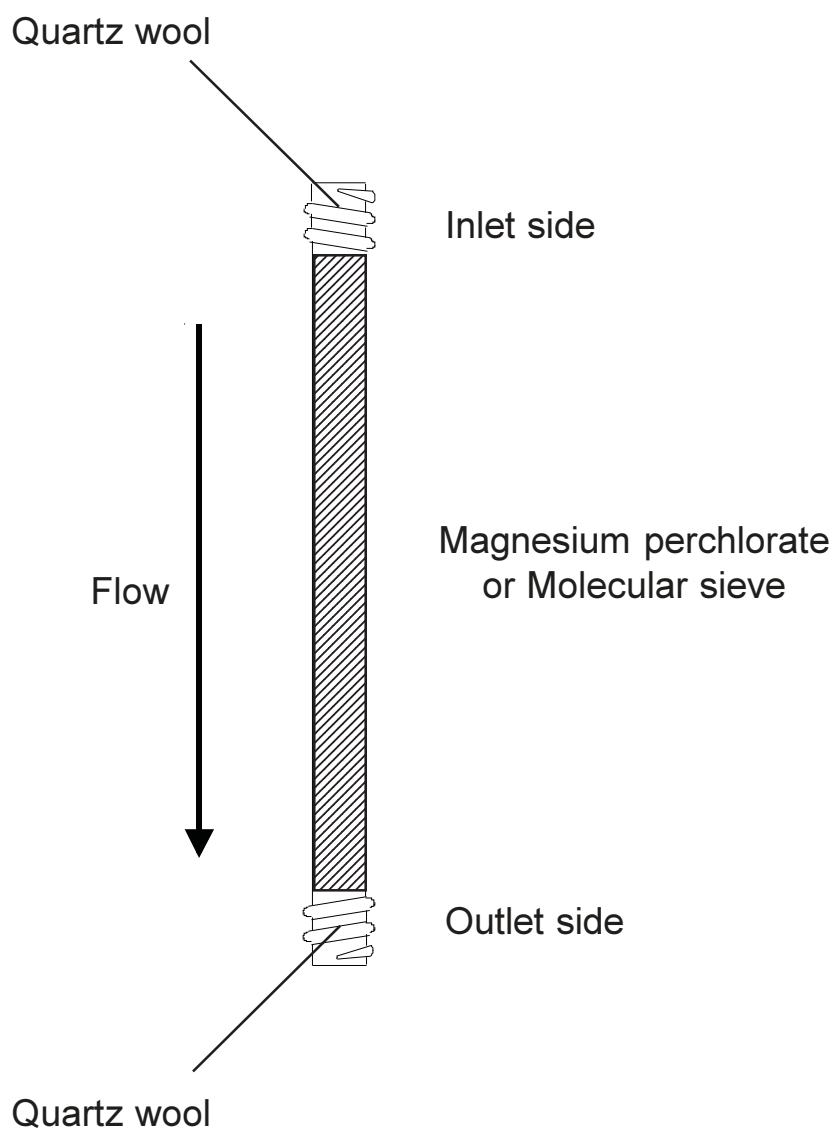

6.3 Installing Reactor, Traps, and Leak Checking

Installing the reactor

Place one of the seals (Part no. 061116) on the top of the combustion reactor and place it in the combustion furnace. This can be done at any temperature, although it may be more comfortably done at the stand-by temperature. Place the autosampler on the reactor and tighten down the large nut. Allow a small flow of Carrier Gas through the reactor by turning on the N₂ regulator (3.1 FRONT VIEW, No.3).

Below the furnace; slide the reactor all the way down into the bottom sealing device (start with the handle all the way to the right side position). Note: make sure the tube is completely down into the sealing device and through the bottom sealing o-ring (inside the device). Once the reactor is installed, move the handle to the left, sealing the bottom of the reactor.

Installing traps

Place a seal on the post of the brass end fitting for the trap, and tighten the red end cap. The seals can be placed with the Teflon side toward the glass trap or the brass fitting.

Leak checking

Once the reactor and trap is installed, a static leak check should be performed. Place a cap on the Carrier Gas vent (to CRDS) (3.1 FRONT VIEW, No.7), wait 10-15 seconds for the pressure to stabilize, then turn the Carrier Gas regulator off (counter clockwise). If there are no leaks the pressure on the carrier gas gauge will remain constant, if a leak is present the gauge will begin to fall. Sometimes the gauge will fall slightly, then remain constant. This only means that not enough time was allowed for the pressure to stabilize. If the pressure remains constant for 30-45 seconds, the Combustion Module is tight enough to operate. If the pressure drops continuously after capping the vent, a leak is present in the system and must be sealed.

6.4 Setting Flow Rates

Carrier

The recommended flow rate for the ^{Nitrogen} carrier gas is between 90-100 ml/min. The flow rate is set by attaching the bubble flow meter to the Vent (to CRDS) and adjusting the carrier gas regulator until the required flow rate is achieved. Increase pressure to increase flow, and decrease pressure to decrease flow. The pressure required to main-

tain the flow rate will be rather low, typically around 0.2 bar. This is due to the short GC column. That pressure should give you a measured flow rate of N₂ carrier gas at about 90-100 ml/min.

Oxygen

The procedure to set the oxygen flow rate is different than the one for Nitrogen This is because the most important consideration is the pressure to be maintained in the oxygen volume rather than the actual flow rate. The pressure in the oxygen volume, along with the size of the volume, will determine the amount of oxygen introduced for each sample combustion. This is very important to control and understand because there must be enough oxygen to combust the sample plus a small excess. Too little oxygen will result in poor or incomplete combustion, too much oxygen will consume the reduction (copper filled) reactor very quickly.

To set the oxygen flow rate; 1) GENTLY close the O₂ Flow metering valve located above the O₂ Vent. Stop when you feel resistance, do not force the valve closed. It need not be completely closed for the set flow rate procedure. 2) Set the pressure required using the Oxygen regulator, it should be set to 1 bar. 3) Attach the bubble flow meter to the O₂ Vent and open the metering valve until a flow rate of about 30 ml/min is reached. This should be adequate to flush the N₂ carrier gas from the O₂ volume and fill the oxygen volume to the correct pressure between sample runs.

7.0 Connecting the start signal cable

7.1 Liaison to Combustion Module

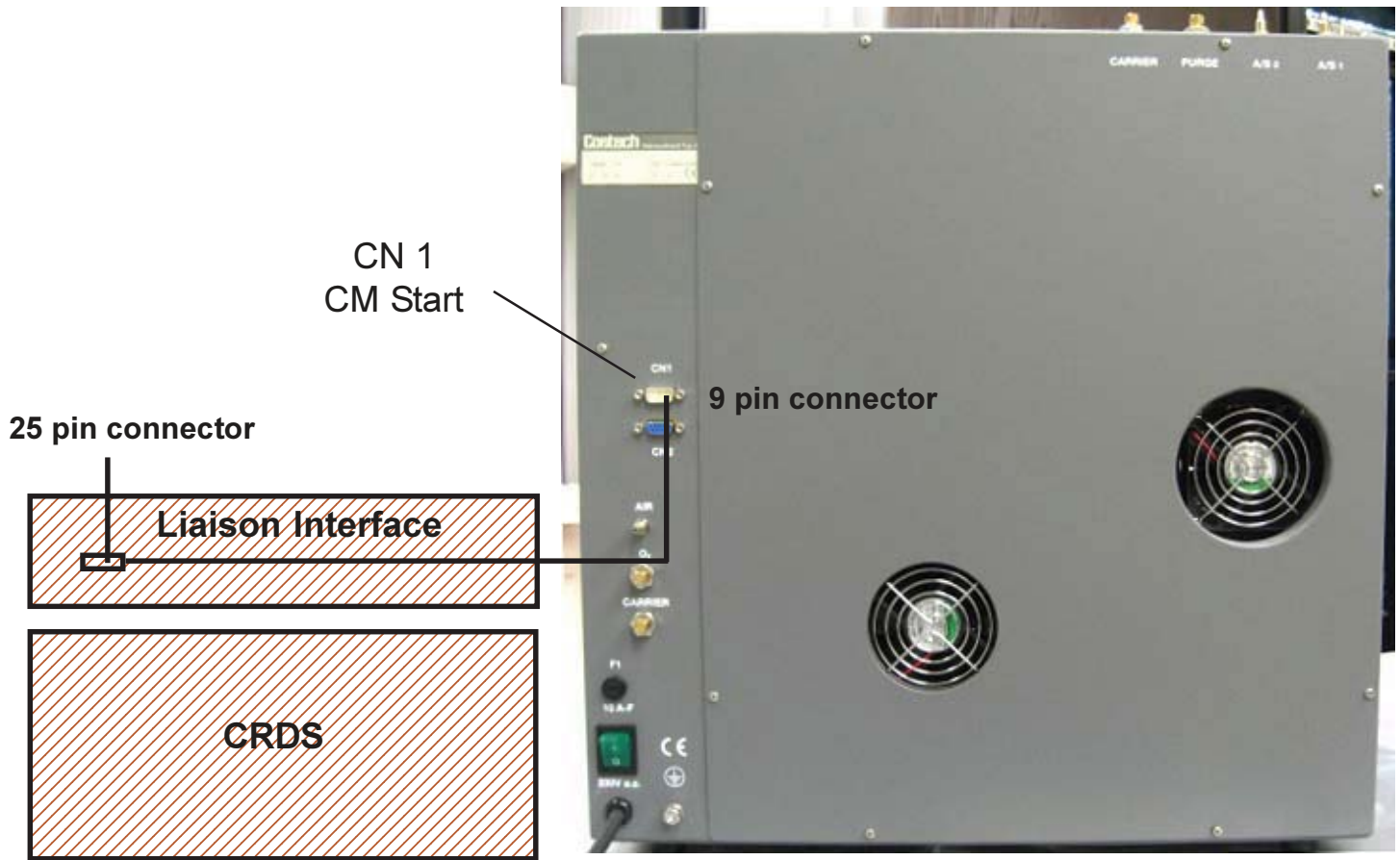

Connect the DB-9 end of the dark grey “Contact Closure” cable to the “CN1” DB-9 Male port on the back panel of the Costech Combustion frontend

8. Operating Parameters

8.1 For high-precision ¹³C isotopic analysis

These are the general operating parameters for automatic CO₂ analysis. Modifications may be necessary for specific sample types or applications.

Combustion Module Mode:	CHNS
Left furnace:	980 °C
Right furnace:	000 (right furnace is not installed)
Column Oven:	075 (column oven is not installed)

With the N₂ carrier gas flow rate set at 90-100 ml/min:

Sample Delay:	18 seconds
Sample Stop:	30 seconds (with pneumatic autosampler)
Oxygen Stop:	40 Seconds
Run Time:	400 seconds

8.2 Performing an Analysis

Check the operating parameters for the CO₂ analysis configuration as outlined in Section 8. If the Combustion Module is in Standby, press “Work”, then confirm by pressing “Enter”. The CM will immediately begin to heat the furnaces to the “Work” condition setpoints. When the set operating temperatures have been reached, all LED’s will turn green, indicating the CM is ready for operation. In the “Work” condition the nitrogen and oxygen flow rates will return to the operating setpoints, and the purge flow will be turned on. Set the CM for Remote operation by pressing the “Remote” button, then “Enter” to confirm. REM will appear in the lower right corner of the display, indicating the ECS is in Remote mode and ready to accept an external start signal from the Liaison Interface.

Load samples in the autosampler

Add samples to the carousel starting from the position which is aligned over the hole and going in a counterclockwise direction. The first sample will drop into the piston of the autosampler. N₂ purge gas is flowing over the sample to purge the area of atmosphere. **Note:** the flat plastic lid must be kept on the autosampler carousel when running analyses. It can be lifted or removed to add samples during the run cycle except when the CM is dropping in a sample.

8.3 Solid sample preparation technique

Select the appropriate capsule for the amount of sample material to be analyzed. Tare the capsule on the microbalance and place it on the sample preparation plate. Use the spatula to fill the capsule with your sample material. Place the sample back on the microbalance, wait for it to stabilize, and record the weight. Remove the capsule and place it back on the sample preparation plate.

Using the forceps, squeeze the top of the capsule closed. Grabbing the capsule on the top at either end, push the ends toward the middle, forming a “Z” shaped fold. Holding the capsule at the bottom with one set of forceps, fold down the top with the other set of forceps. Form the capsule into a roughly spherical shape. Avoid flattening the capsule as this can cause jamming in the autosampler. Load the samples in the autosampler as described in section 8.2

8.4 Principle of Operation

The Combustion Module works by the principle of flash combustion. This means a fast sample combustion and conversion to the gases of interest. The flash combustion is achieved by the reaction of the tin sample capsule and pure oxygen introduced for each sample analysis. This reaction drives the local temperature around the sample to 1600-1800 °C. The sample is broken down into its elemental components; N_2 , CO_2 , H_2O , SO_x , and excess Oxygen not used for the sample combustion.

The chromium oxide catalyst in the combustion reactor ensures 100% conversion of the combustion products to the gases of interest. The excess oxygen is adsorbed by the copper wires, and any sulfur is retained by the silvered cobalt oxide.

H_2O is retained by the magnesium perchlorate in the water trap

Since the CM uses N_2 as the carrier gas the only gas which will be measured is the CO_2 . The CO_2 gas is moved through the system by the N_2 carrier gas and exits the CM at the port labeled CRDS. A stainless steel transfer line delivers the gas to the Liaison Interface where it is captured in a gas bag and pumped into the CO_2 analyzer for the isotopic measurement.

Once the samples have been loaded in the autosampler carousel, control of the system is through the CRDS software. At the start of each analysis the Liaison will send a start signal to the CM initiating an instrument cycle. When the CM begins an analysis RUNNING will be displayed in the LCD panel.

8.5 Analysis Cycle

Oxygen is continuously flowing through the CM oxygen system at a rate of approximately 30 ml/min. This O₂ flow exits the CM at the V O₂ (Oxygen Vent) in the front of the instrument. Nitrogen carrier gas is continuously flowing at a rate of 90-100 ml/min through the analytical circuit of the CM (autosampler, combustion reactor, water trap, GC column) and exits the CM at the port CRDS where it flows to the Liaison.

At the start of the CM cycle the N₂ carrier gas is switched via electrovalves into the oxygen system where it pushes the oxygen in the O₂ volume into the analytical circuit. This “plug” of O₂ is brought to the combustion reactor by the N₂ carrier gas and the sample is dropped into the reactor (at 980 °C) 1-2 seconds prior to the arrival of the oxygen. The tin capsule melts into the sample, the oxygen reacts with the tin, and the flash combustion of the sample occurs.

At the time set for the Oxygen Stop, the two systems disengage and O₂ only flows through the oxygen system, flushing out the residual N₂ and filling the oxygen volume for the the next sample analysis.

8.6 Replacing the Ash Crucible

NOTE: Whenever opening the system to atmosphere safety glasses must be worn.

Prepare the Alumina Ash Crucible which catches the residue from the sample combustion. 1 cm of quartz wool is packed into one end of the crucible to provide a “bed” for the sample residue and approximately 2-3 mm of the chromium oxide catalyst (in the installation kit) is placed on top of the quartz wool. The chromium oxide catalyst is the same as that in the combustion reactor. Its function in the crucible is to provide a solid base for the collection of the sample residue; it does not melt or sinter at high temperature during the sample combustion (1600-1800 °C).

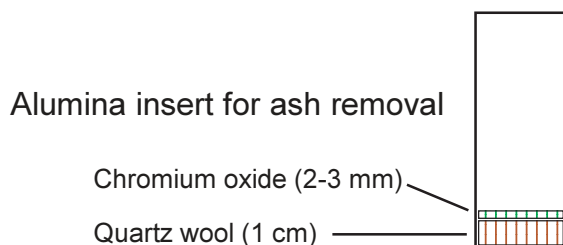

The gases should be in the Standby condition before opening the system to atmosphere. If the CM is in the Standby state (Stby is shown in the display), the gases are already in standby. If you are in the Work condition (Work is shown in the display) press the F3 key on the keypad which puts only the gases into standby, leaving the furnace at full temperature.

Loosen the large nut connecting the autosampler to the combustion reactor and slowly vent the system. Lift the autosampler slightly and move it off of the reactor and to the side being careful not to damage the top of the quartz tube. Using the tongs provided insert them

9.0 Sample Preparation

9.1 Sample Preparation Tools

The Combustion Module will be delivered with the basic tools required for solid sample preparation.

Sample preparation plate:

A metal plate with holes for holding sample capsules while filling the capsules

Sample plate

A metal plate with holes for holding samples before putting them in the autosampler carousel

Spatula

For filling the capsules.

Forceps

For closing the solid sample capsules.

9.2 Liquid sample preparation technique

The easiest way to handle liquid samples is to treat them as solid samples if possible. For example, if the liquid sample is relatively non-volatile, it can be absorbed onto a solid material such as Chromosorb W. Add Chromosorb W (enough to absorb the liquid) to a standard solid capsule and tare it on the microbalance. Add the liquid by pipette, syringe or wire, taking care that the sample is completely absorbed into the Chromosorb W. Seal the capsule as described above (section 9.3), and place it on the microbalance. When it stabilizes, take the weight. If the sample weight does not stabilize, then the samples are not suitable for this technique and must be sealed in the special liquid capsules.

9.3 Capsules

Capsules for solid samples

Part no.	Description	Qty.
041060	Tin capsules, 3.5x5 mm	100
041074	Tin capsules, 3.5x5 mm	250
041061	Tin capsules, 5x9 mm	100
041077	Tin capsules, 5x9 mm	250
041070	Tin capsules, 4x6 mm	250
041073	Tin capsules for large samples, 9x10 mm	100
041066	Silver capsules, 3.5x5 mm	100
041072	Silver capsules, 4x6 mm	250
041067	Silver capsules, 5x9 mm	100

Capsules for liquid samples

041062	Tin capsules, 2.9x6 mm	100
041063	Tin capsules, 2x5 mm	100
041064	Tin capsules, 1x5.5 mm	50
041065	Tin capsules, 3.5x9 mm	50